

# Fact & Fiction in Cosmology

Ned Wright, UCLA

6 May 2005

# Fact: Gravity Rules

- Gravity is a long-range, always attractive force, and dominates the Universe at large scales.
- Newton's law for gravity is  $F = -GMm/d^2$ .
  - or  $g = -GM/d^2$  independent of the nature of the mass “m”.
- Need to know the DISTANCE “d” in order to have an inverse square law.

# Definitions

- Distance – the spatial separation of the positions of two objects taken at the **SAME TIME**.
  - $d = \| x_1(t) - x_2(t) \|$
  - $d \neq \| x_1(t_1) - x_2(t_2) \|$  with  $t_1 \neq t_2$ .
- Recession velocity “v” is the change in the distance during a time interval divided by the duration of the time interval
  - $v = [d(t_2) - d(t_1)] / [t_2 - t_1]$

# But, but, but ...

- Special relativity says that the concept of simultaneity for spatially separated events cannot be defined in an invariant manner.
- Time dilation: moving clocks run slow.
- Einstein wanted to replace Newton's inverse square force because the DISTANCE that went into Newton's Law was not defined in SR.
- General relativity was the result. "General" means invariant under general coordinate transformations.



# Space-Time Diagrams

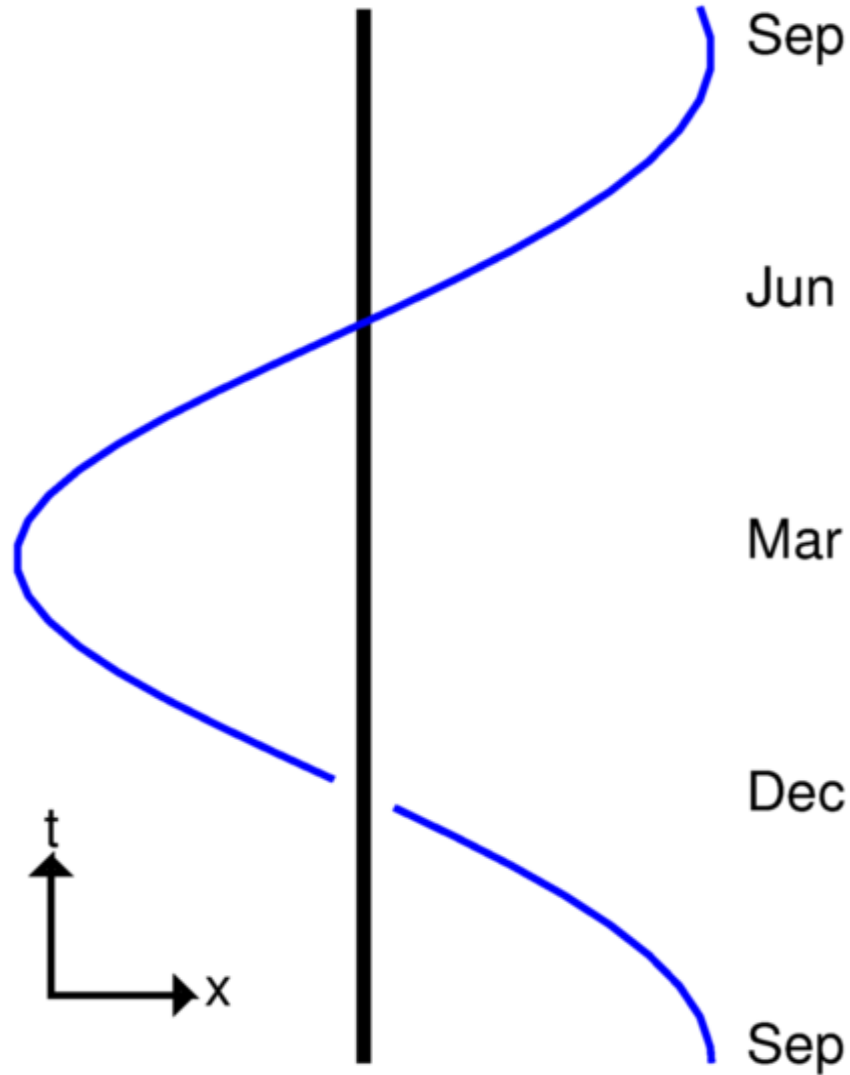

# Galilean Relativity

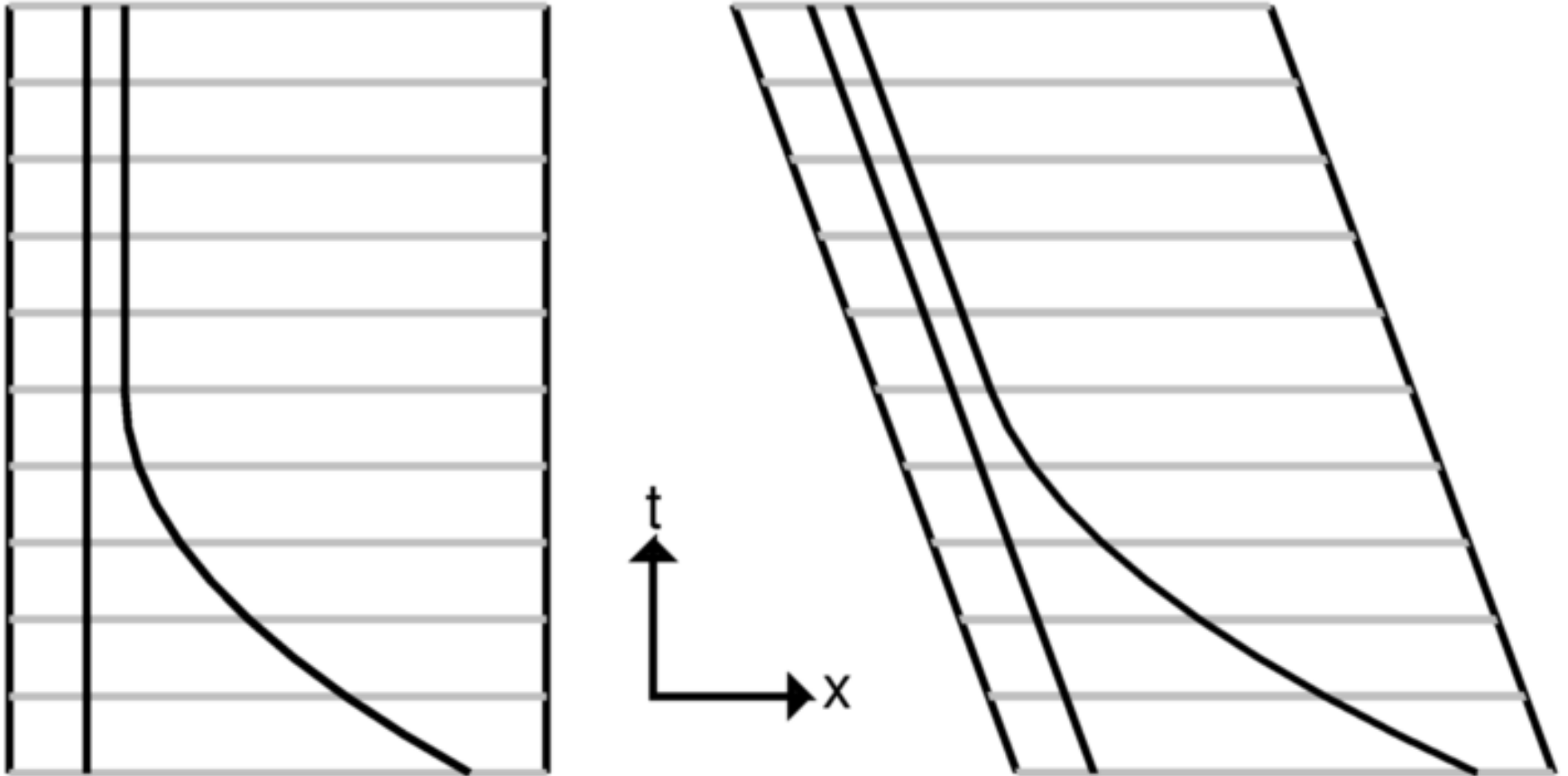

- Only allowed transformations are “skewing the deck of cards with a straightedge.”

# But Let There be Light(speed)

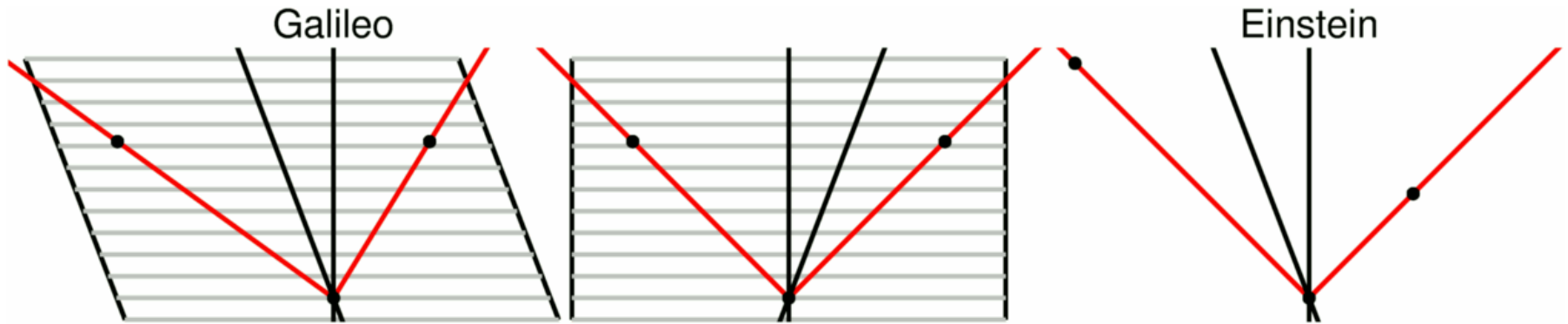

- A constant speed of light violates Galilean relativity, so SR uses Lorentz transformations.
- Middle ST diagram transforms into unequal speeds of light under Galilean transformation [left], while Lorentz transformations [right] preserve the speed of light but not simultaneity.

# Lightcones are fundamental

- In SR lightcones transform onto themselves but not in GR: they can tilt or stretch.
- “Speed Limit 300,000 km/sec” only means worldlines of objects have to be inside their local lightcone.

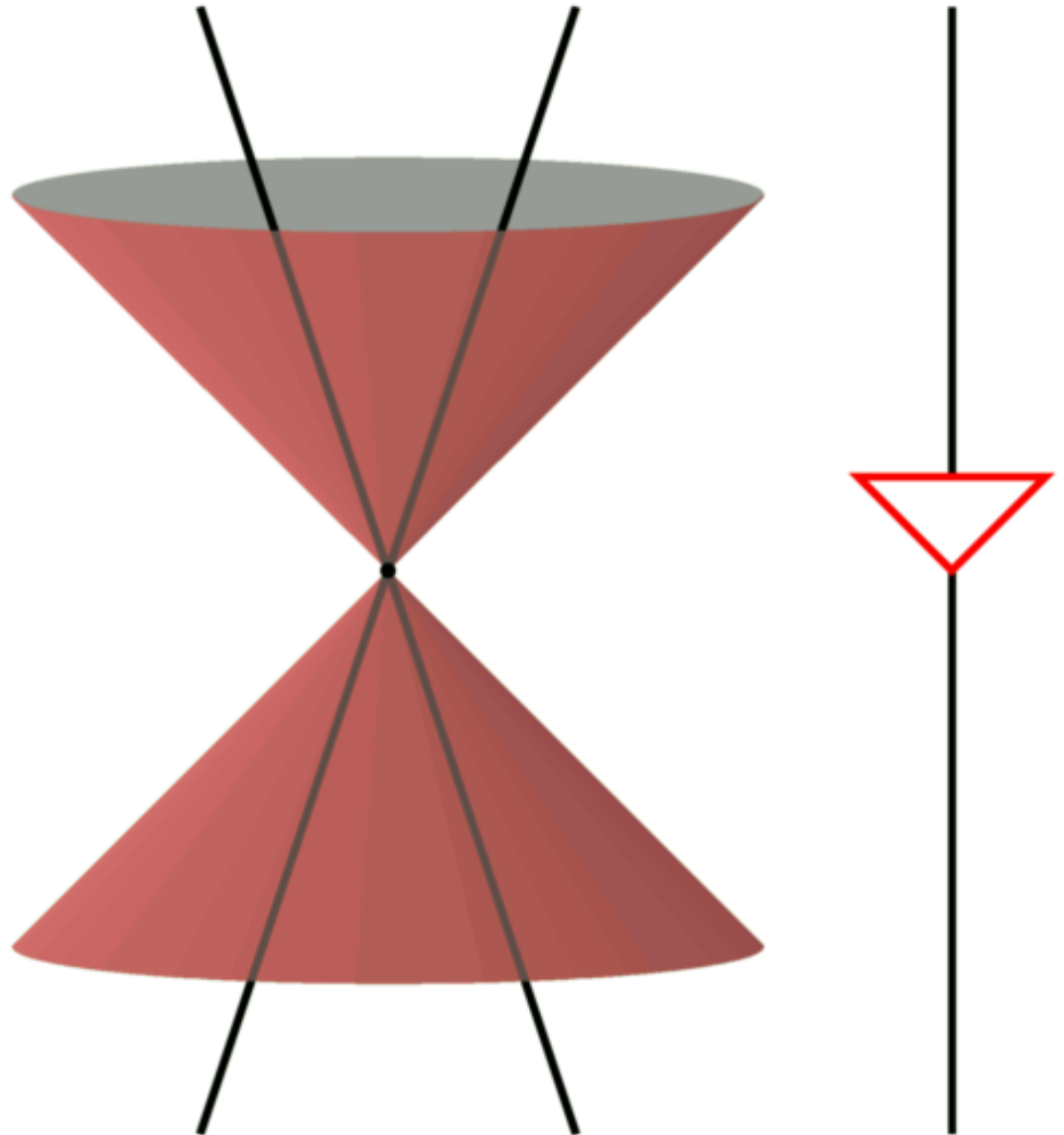

# A General Transformation

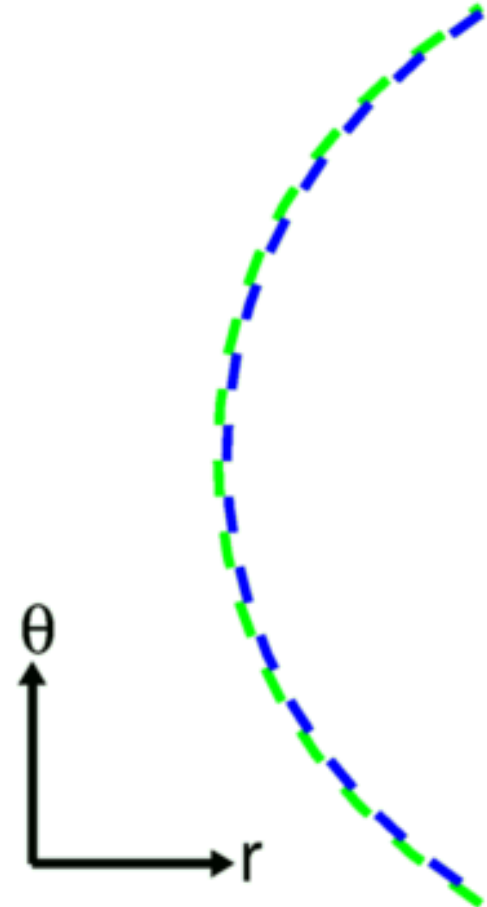
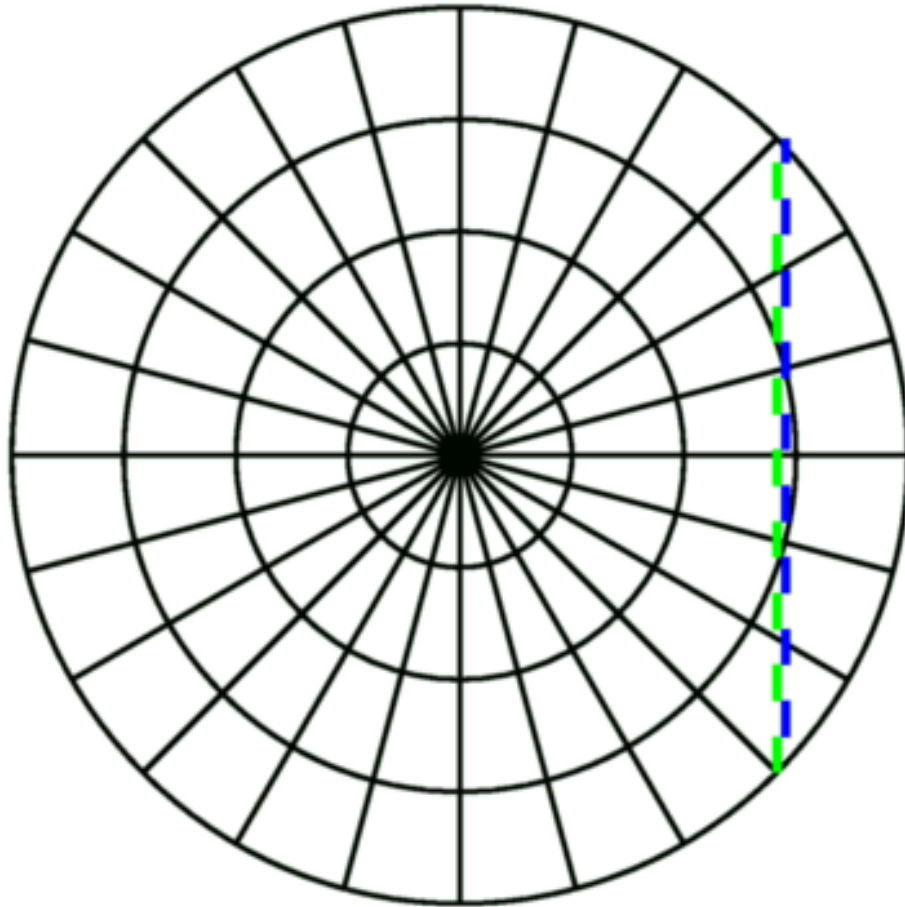

- “Straight” world lines become curved but with the same acceleration for all objects: just like gravity.

# A General Transformation

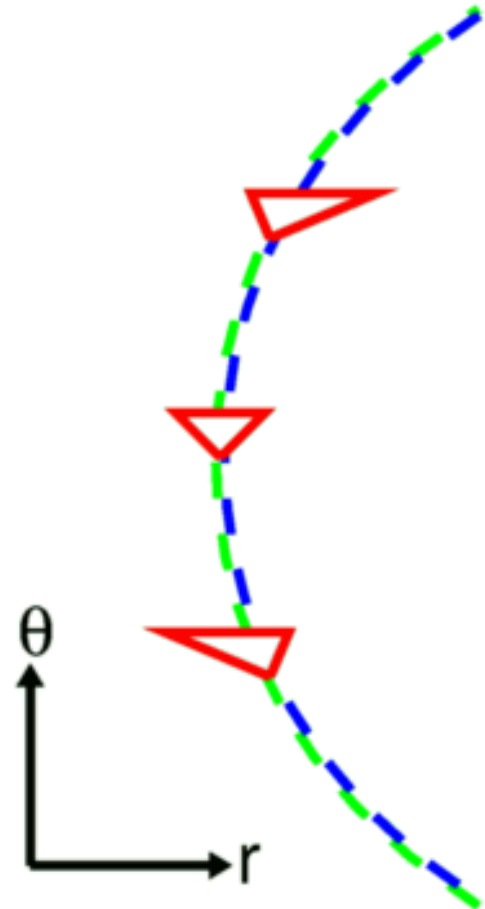
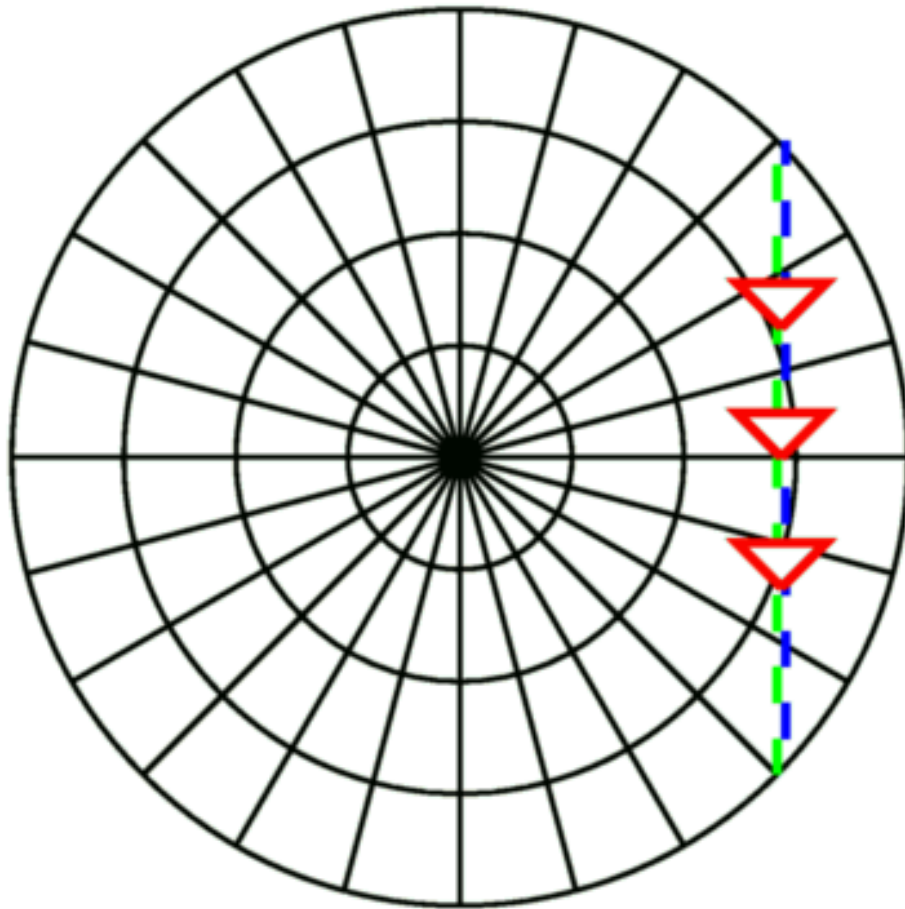

- The light cones tip over in a general coordinate transformation.

# Fact: The Cosmological Principle

- The Universe is homogeneous and isotropic.

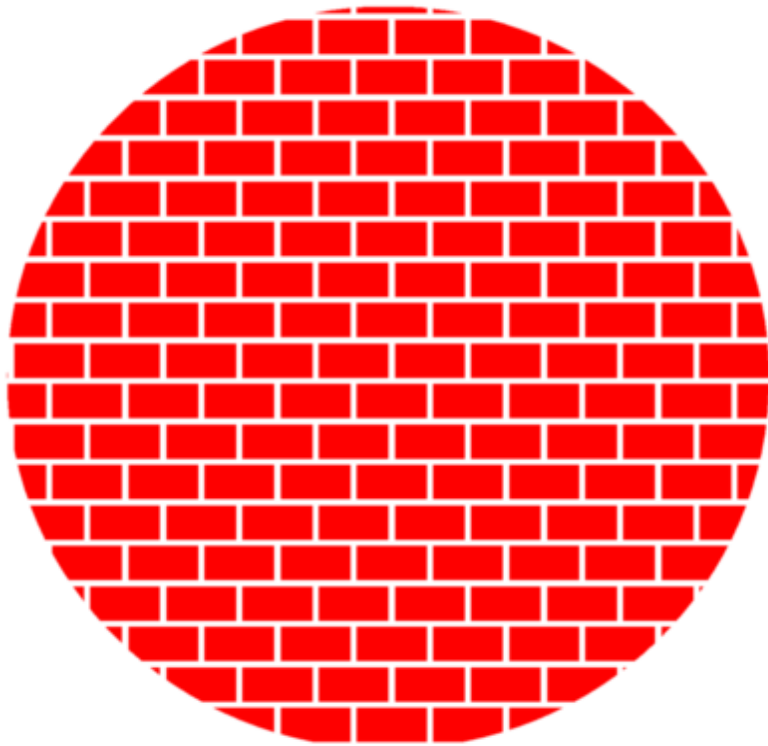

Not isotropic

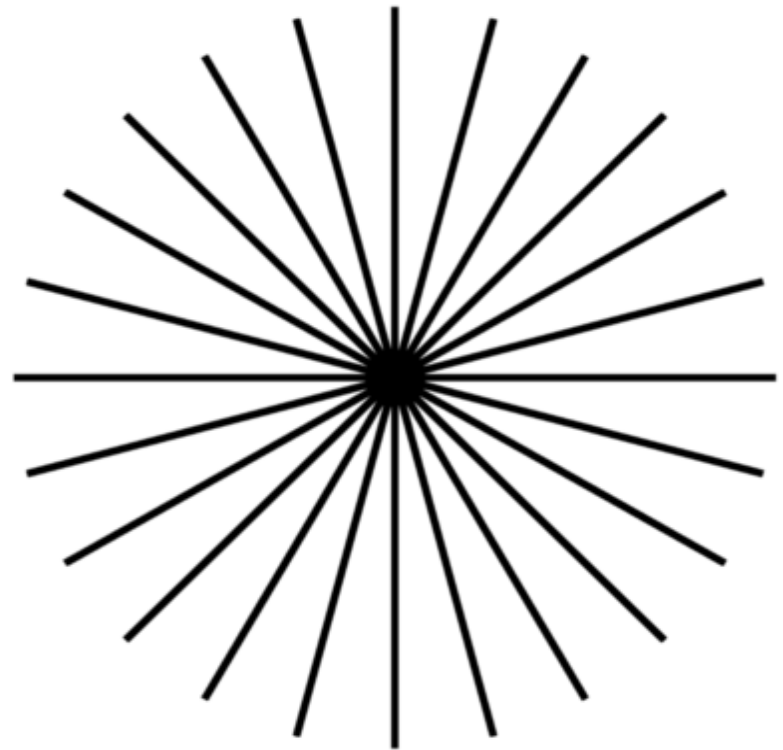

Not homogeneous

# Larger Scale Homogeneity

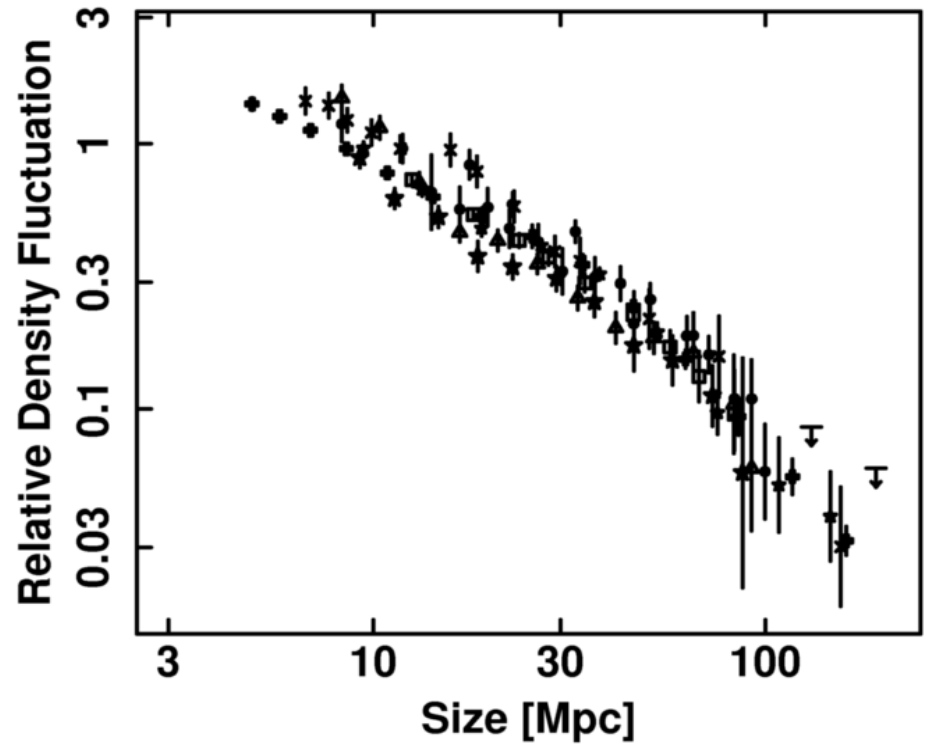
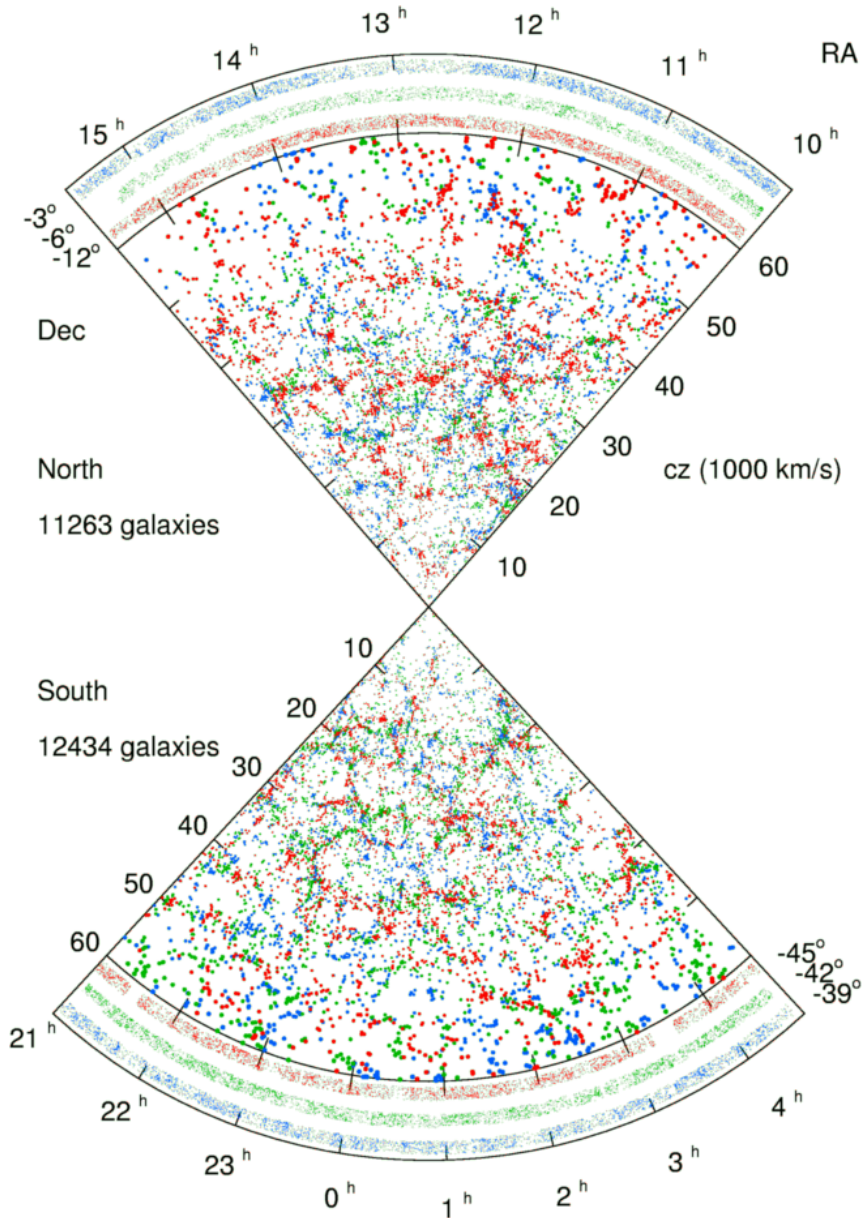



# Isotropy of Radio Source Counts

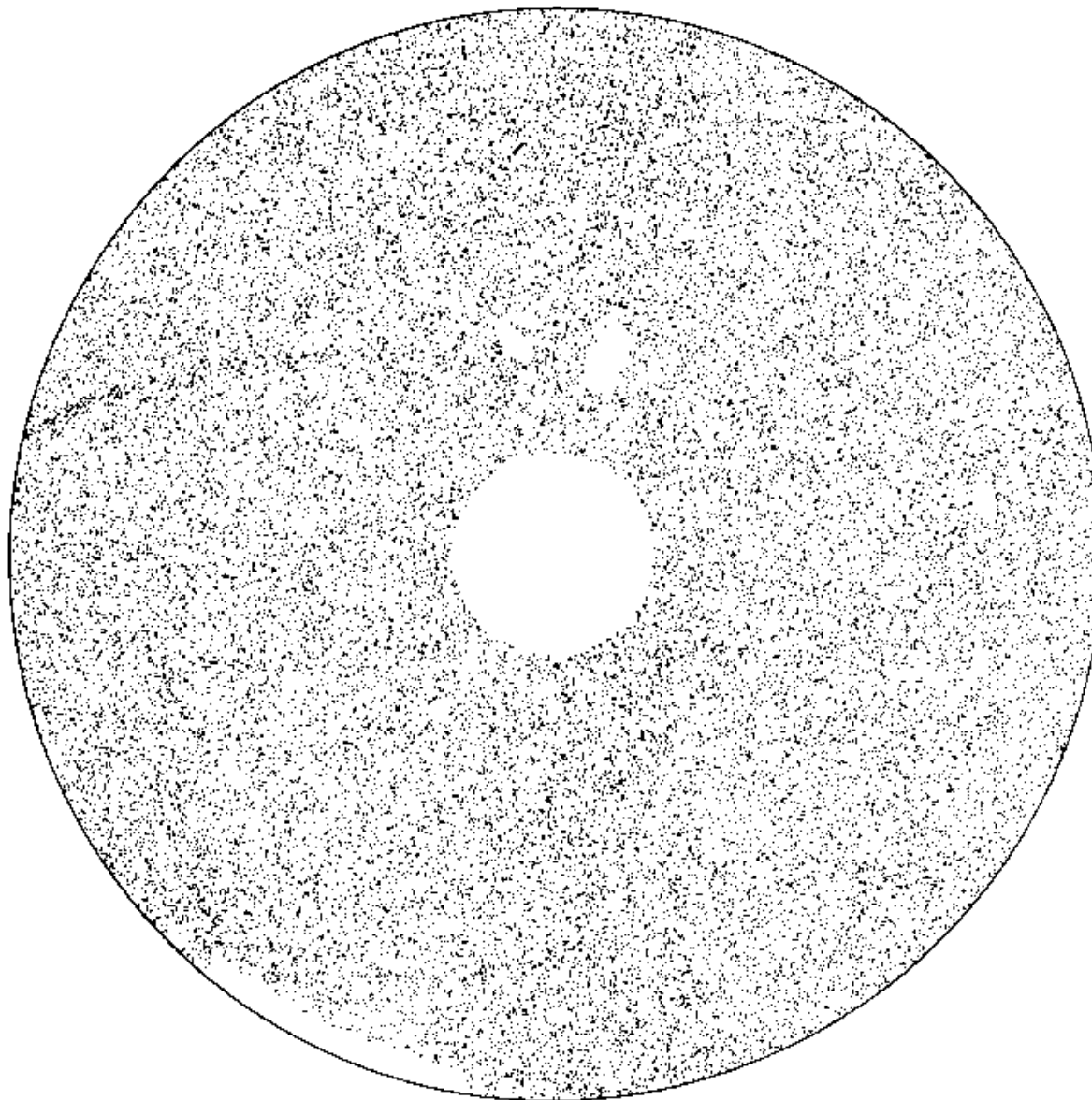

# Fact: the Hubble Law, $v=HD$



Edwin Hubble

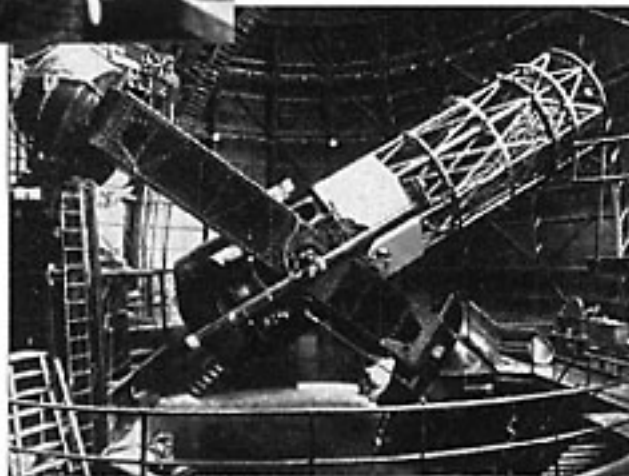
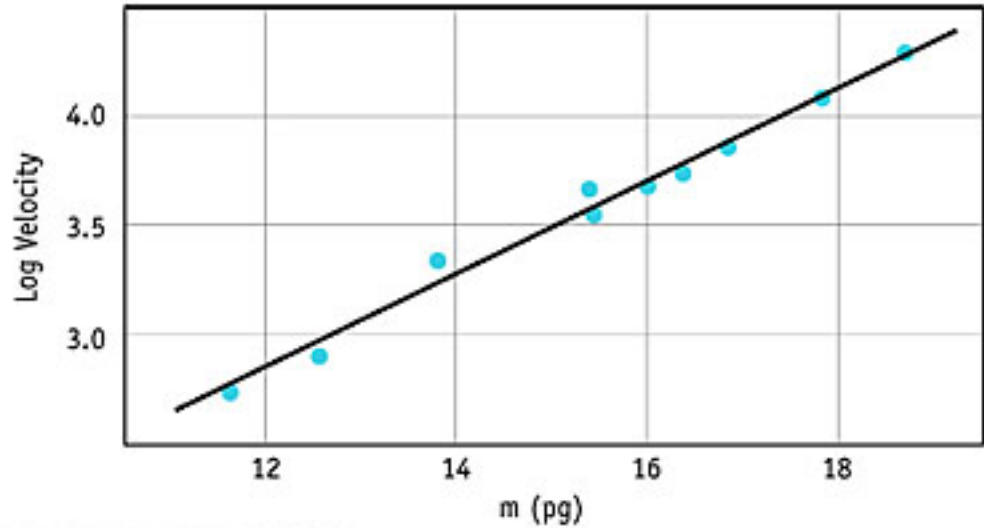

Mt. Wilson  
100 Inch  
Telescope

# Velocity from Doppler shift

OBJECT RECEDING:  
LONG RED WAVES

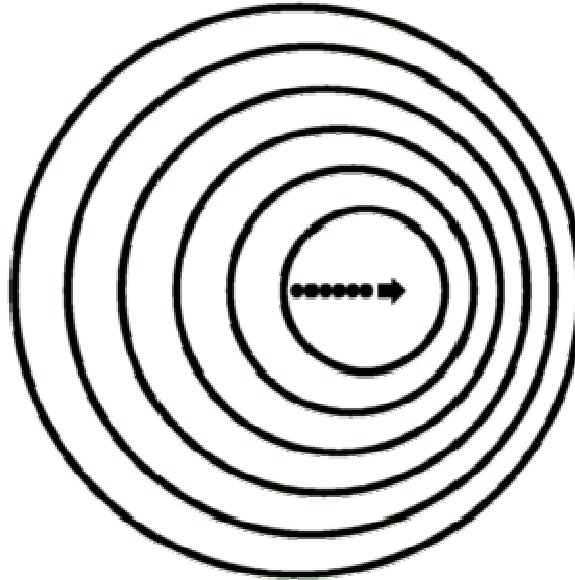

OBJECT APPROACHING:  
SHORT BLUE WAVES



- $1+z = \lambda_{\text{obs}}/\lambda_{\text{em}}$
- $v \approx cz + \dots$

# Fainter galaxies $\rightarrow$ more redshift

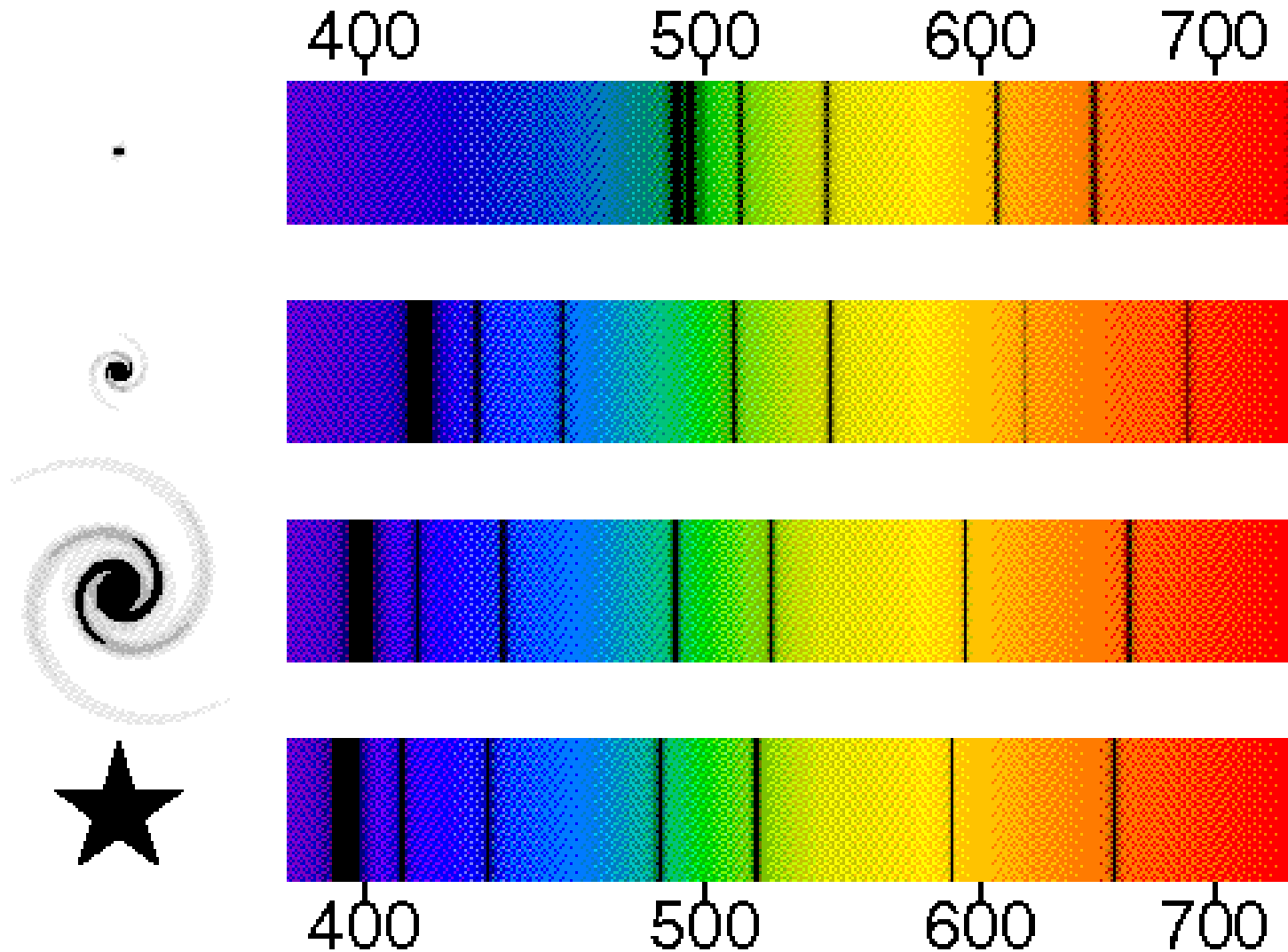

# Define Cosmic Time

- The Hubble law is only true in one frame of reference, the comoving frame.
- An observer moving with respect to that frame would see excess velocities:

– Blueshifts in front:

– Redshifts behind:

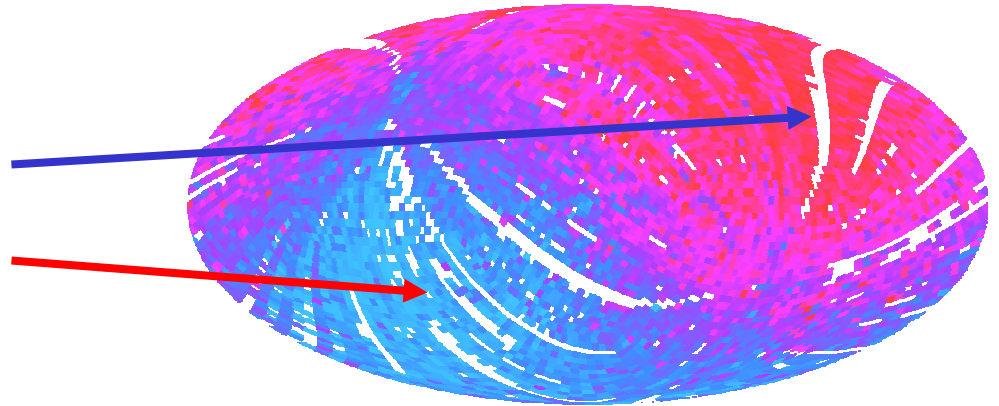

- Therefore the cosmic time, the age of the Universe measured by a comoving observer, can be defined.

# Linear v vs D law is universal

Linear:

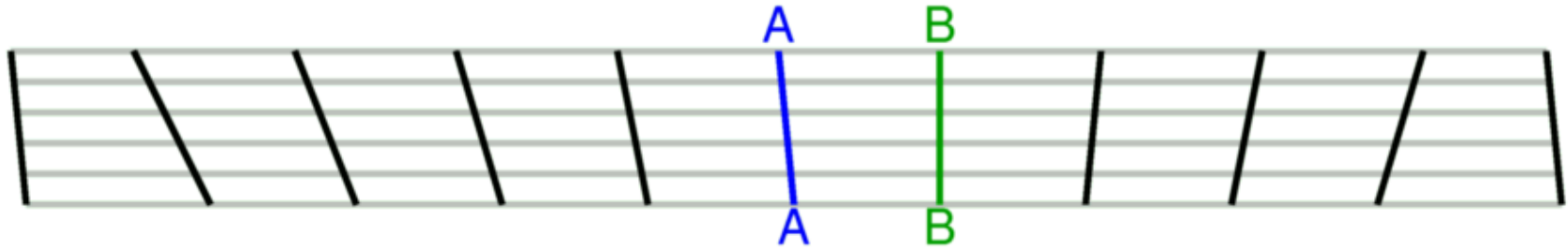
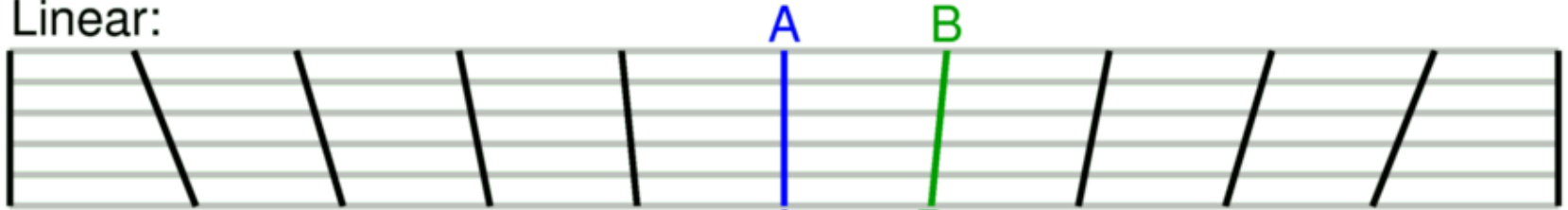

Quadratic:



# Linear v vs D law does not distort



$v \propto \text{const}$

$v \propto D$

$v \propto D^2$

# Cosmological Spacetime

- Use proper time since Big Bang for comoving observers as the time variable.
- Use radar distance measured by comoving observers for small distances.
  - Hence light cones are symmetric about worldlines of comoving observers. Speed of light is “c” relative to local comoving observers.

Linear:

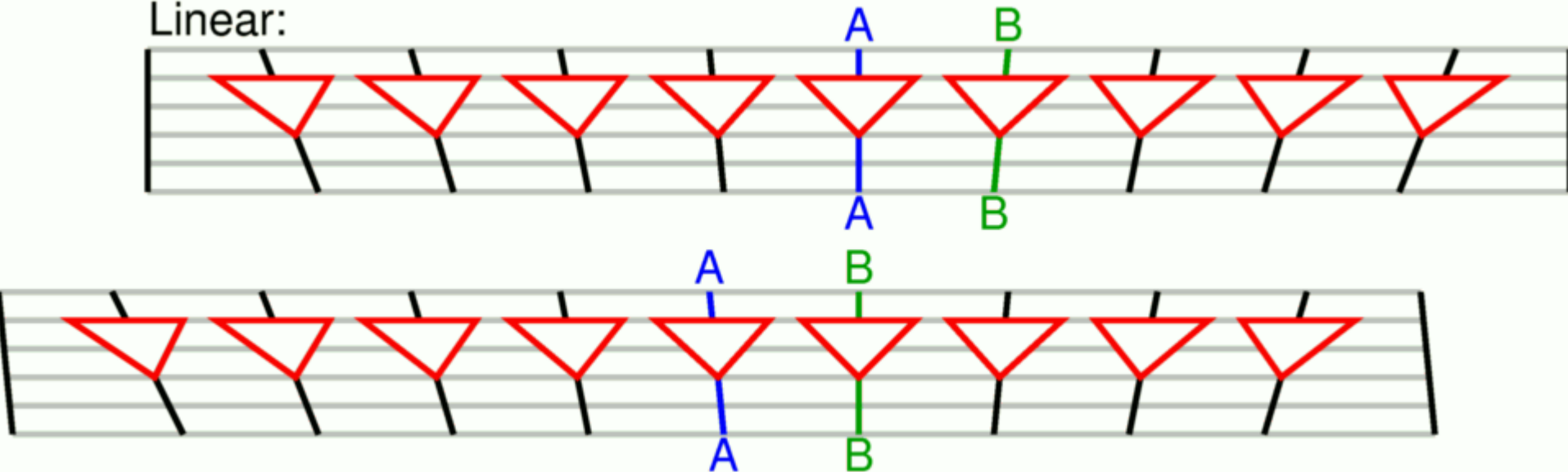



# $v > c$ is inevitable

- Over long distances sum up many short distances.
- Hubble law  $v = HD$  applies exactly so  $v > c$  is inevitable for large distances.



- Where the lightcones are tipped past the vertical, galaxies are receding faster than  $c$ .

# These rules give this ST diagram

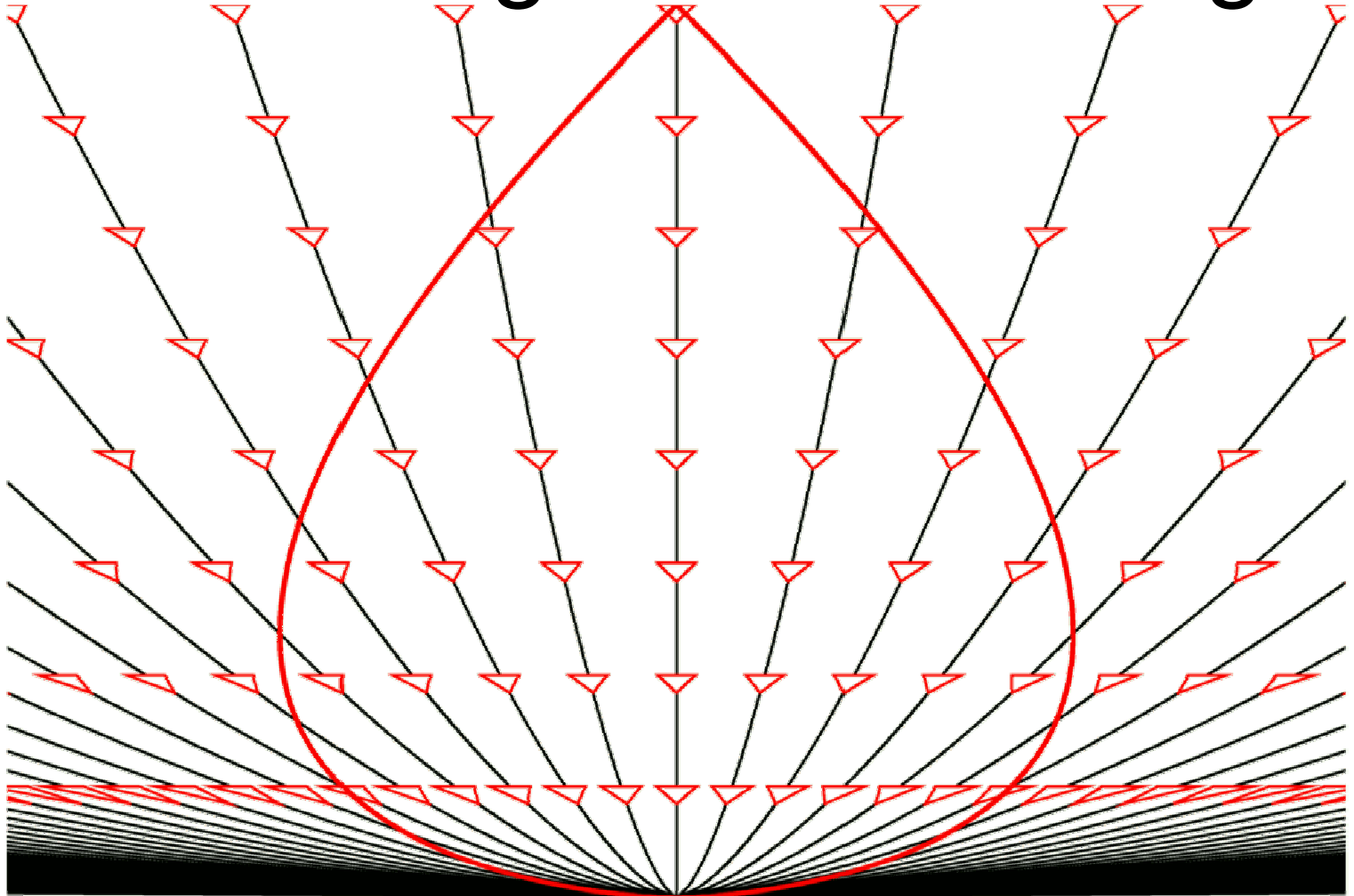

The “teardrop” is always parallel to the sides of the little light cones, so it is our past light cone, and marks the part of spacetime we can see.

# A New Deck of Cards

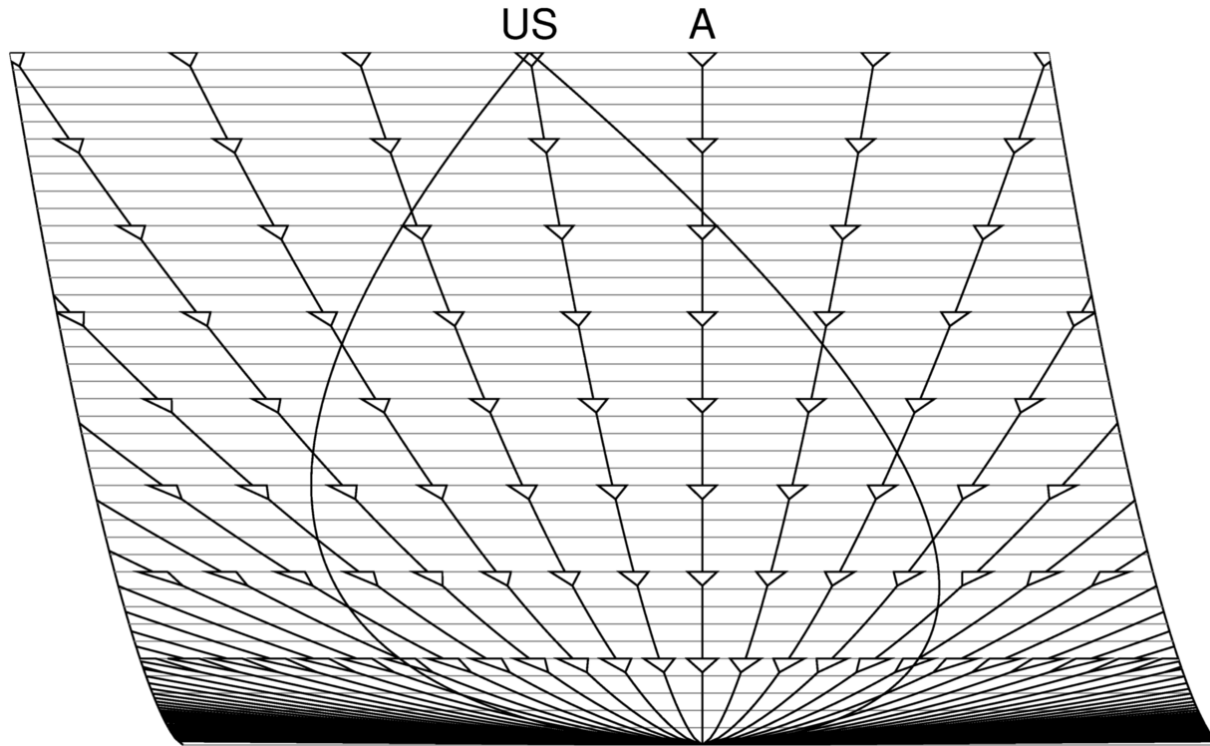

- With cosmic time we are back to skewing a deck of cards. But now the edge can be curved – it must follow the worldline of a comoving observer.

$(v/c)_{\max} = \infty$  for viable models

$\Omega_m$	0	0.27	1	6.43	0.27	0
$\Omega_\Lambda$	0	0	0	0	0.73	1
Max (v/c)	$\infty$	$\infty$	$\infty$	1.35	$\infty$	$\infty$
(v/c) at $z=\infty$	$\infty$	2.91	2	1	3.38	$\infty$

$H_0 = 71, \Omega_r = 0$

# Other “distances”

- The distance  $D_{\text{now}}$  used in the Hubble law is hard to measure.
- Measurable distances are:
  - the redshift.
  - the luminosity distance based on the inverse square law.
  - The angular size distance based on the apparent angular sizes of objects.
- Other unmeasurable distances include the “light travel time distance,”  $D_{\text{ltt}}$ .

# Many Distances

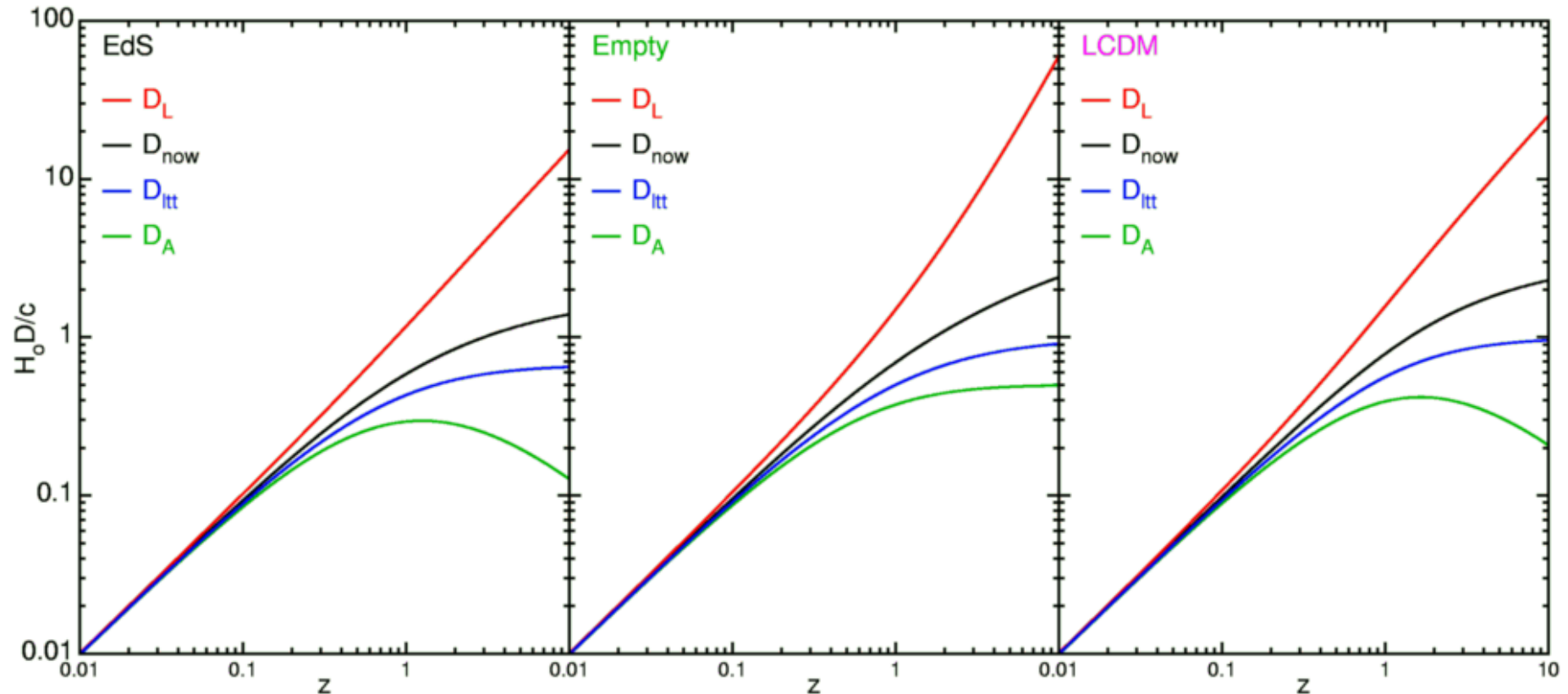

- $D_A = \text{size}/\theta$        $D_L = (L/4\pi F_{\text{bol}})^{0.5}$        $cz/H_0$
- $D_{\text{ltt}} = c^*(t_o - t_{\text{em}})$
- $D_{\text{now}}$  = sum of distance between neighbors along the path  $t = t_o$  in space-time.

# $D_{\text{ltt}}$ is often used in press releases

- The redshift is thought to be too complicated.
- The radial proper distance  $D_{\text{now}}$  is thought to be too complicated.
- But  $D_{\text{ltt}}$  only delays the complications long enough to let the presenters at the press conference get out the door.
  - “If we see a quasar 1 billion years after the Big Bang that is 12.7 billion light years away ( $D_{\text{ltt}}$ ), how did it travel 12.7 billion light years in only 1 billion years?”

# Light travel time: Why $D_{\text{ltt}}$ is $D_{\text{umb}}$

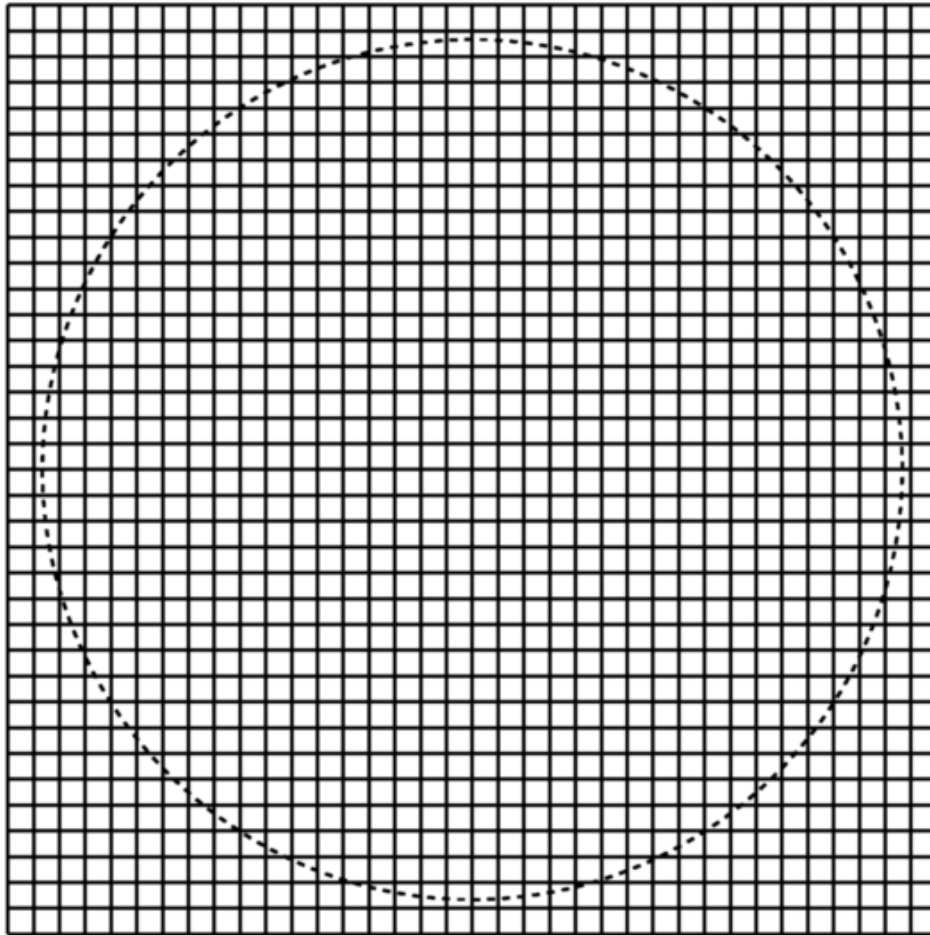

$D_{\text{now}}$

$D_{\text{ltt}}$



- Light travel time distance violates the cosmological principle: the Universe is neither homogeneous nor isotropic.



# $D_{\text{Itt}}$ does not satisfy the Hubble law

- Velocity is not strictly proportional to distance when using  $D_{\text{Itt}}$ :
- The deviation depends on the cosmological model.

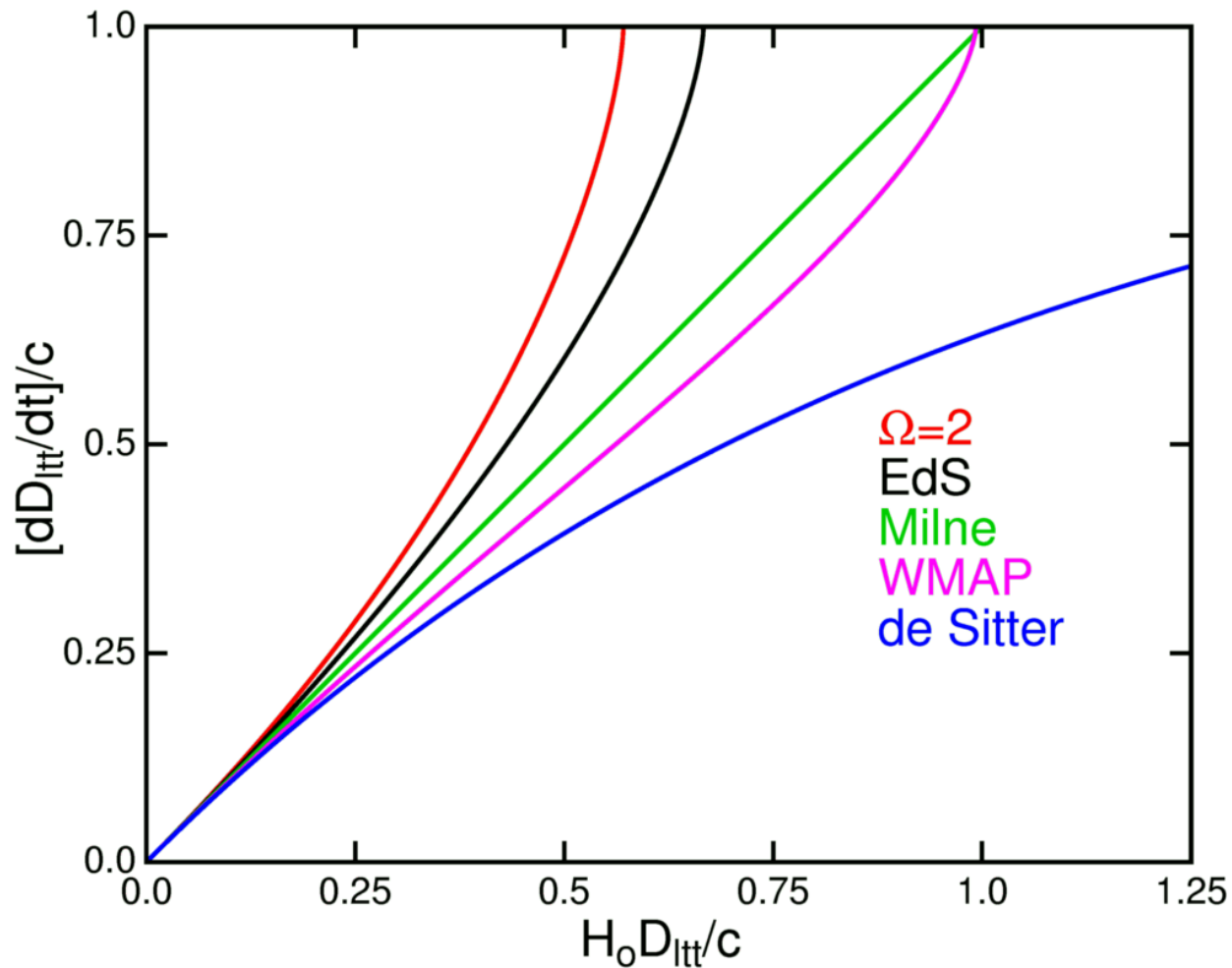

# Great Taste or Less Filling?

- Is the redshift due to a Doppler shift or is it just the effect of an expansion of space? Please remember that in GR an arbitrary change in coordinates is allowable.
- So use the coordinates that give the simplest solution. GR guarantees that observables like the redshift will be unchanged so either
  - Fixed comoving coordinates with expanding space, or
  - Proper radial distances with Doppler shift will give the same  $z$  if computed correctly.
- But  $1+z = ((1+v/c)/(1-v/c))^{0.5}$  is never right.

# A Bound Cluster does not expand

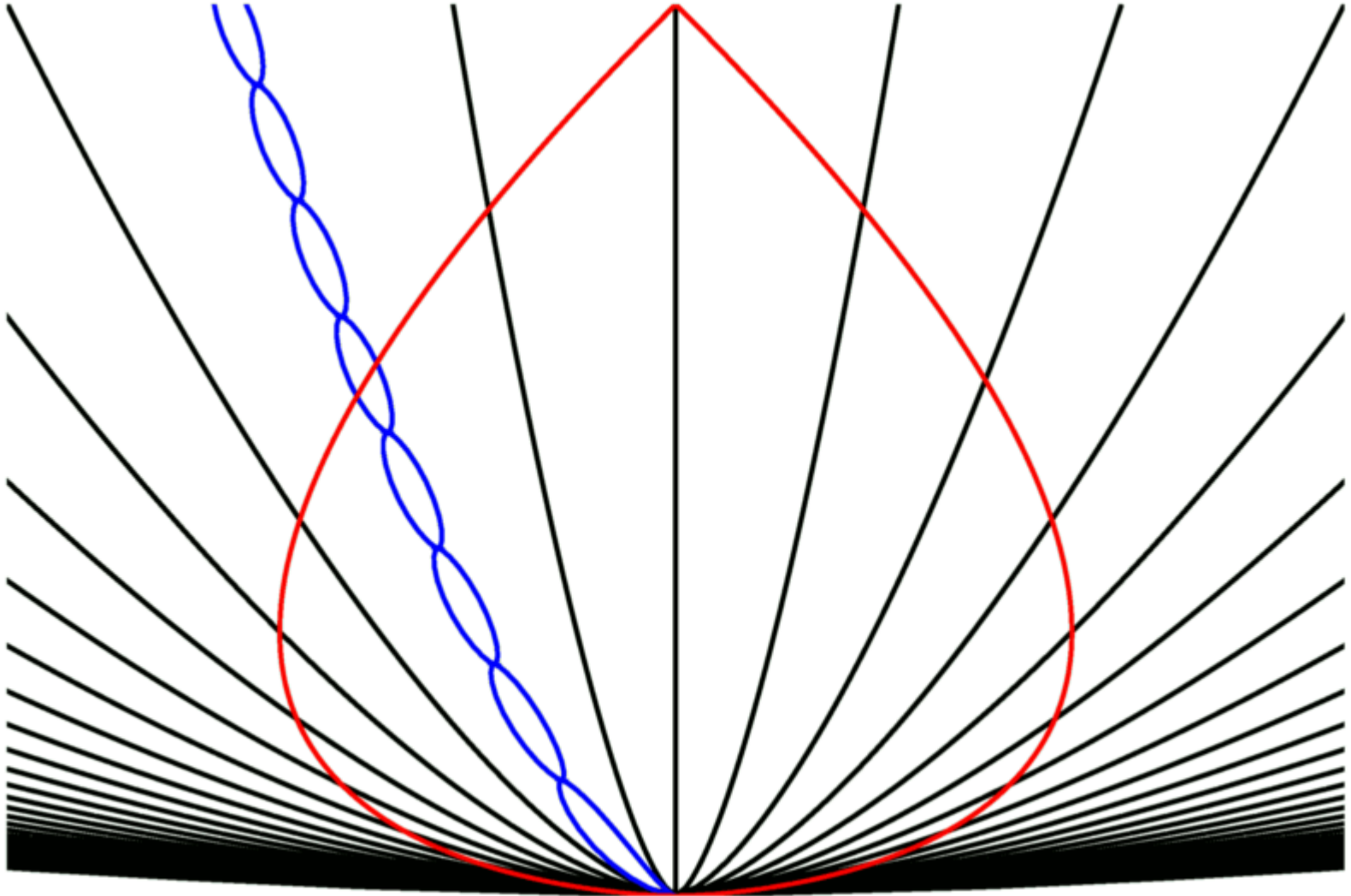

# Use the simplest coordinates

- Centered physical coordinates [moving galaxies] allow a simple calculation.
- Comoving coordinates [expanding space] are much more complex here.

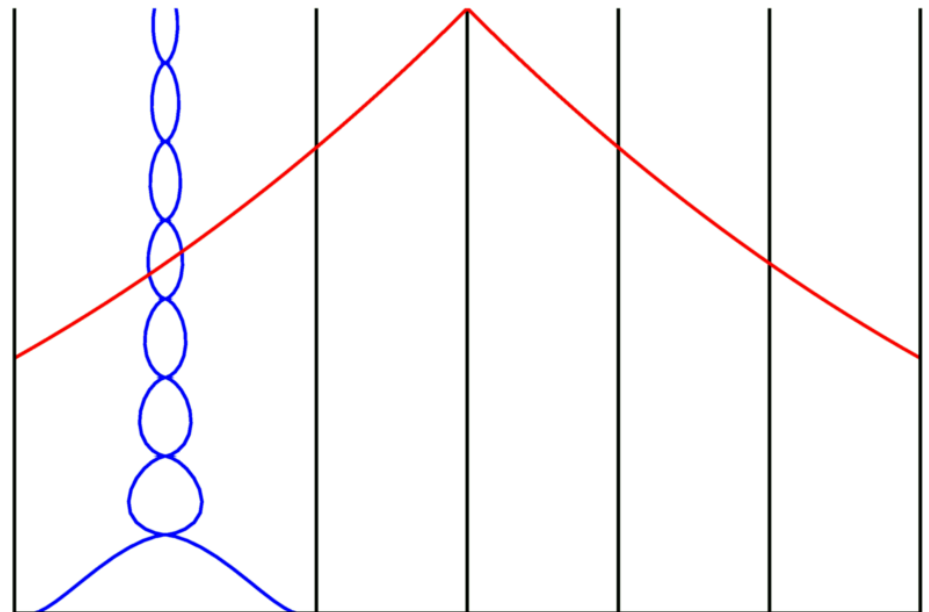
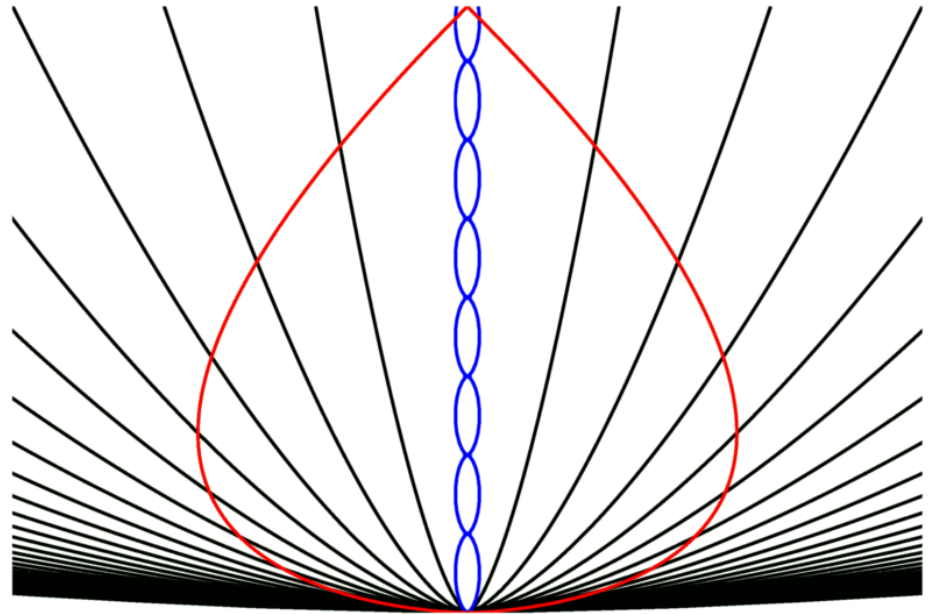

# Recap on $v > c$

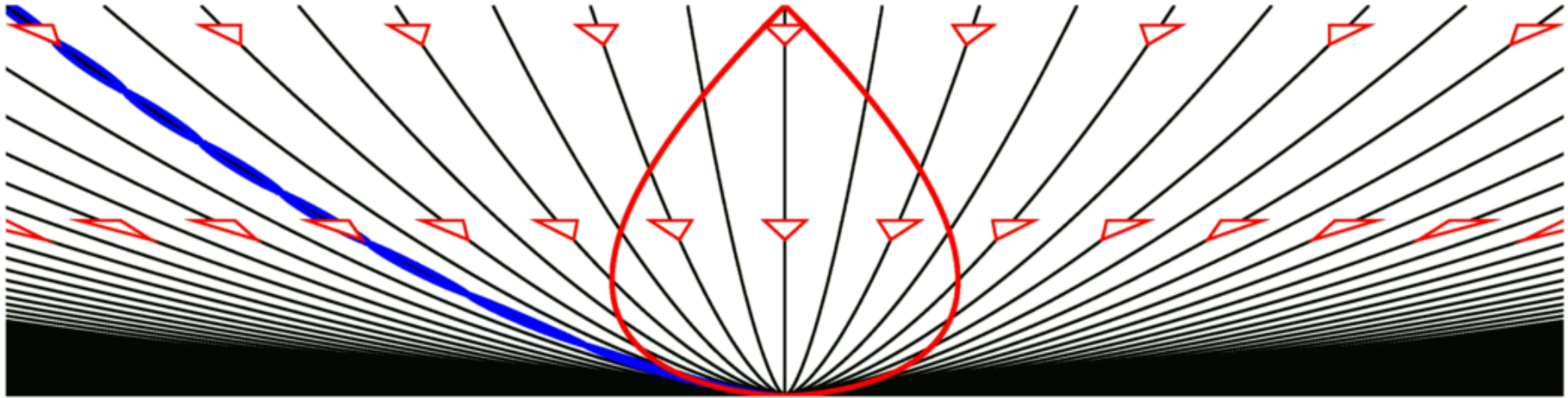

- Very distant bound cluster with recession velocity  $> c$  but the worldlines of the objects in the cluster are well within the local lightcone.

# “Normal” vs Conformal ST Diagram

- Constant SE course is a curve on the globe but a straight line on the conformal Mercator map.
- Constant speed-of-light is a curve on the “normal” space-time diagram but a straight line on the conformal diagram.

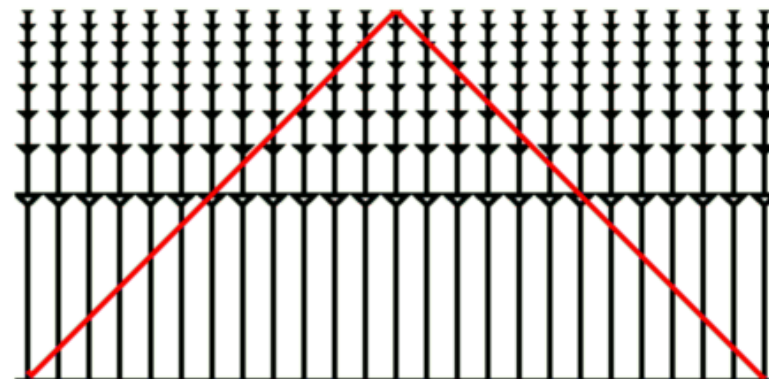
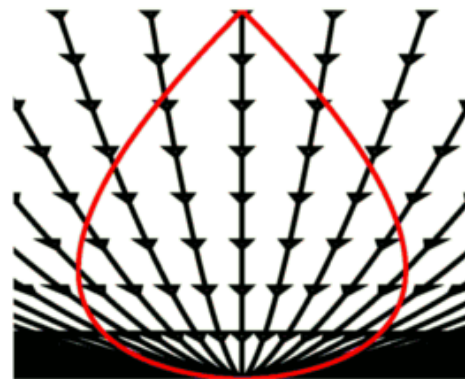
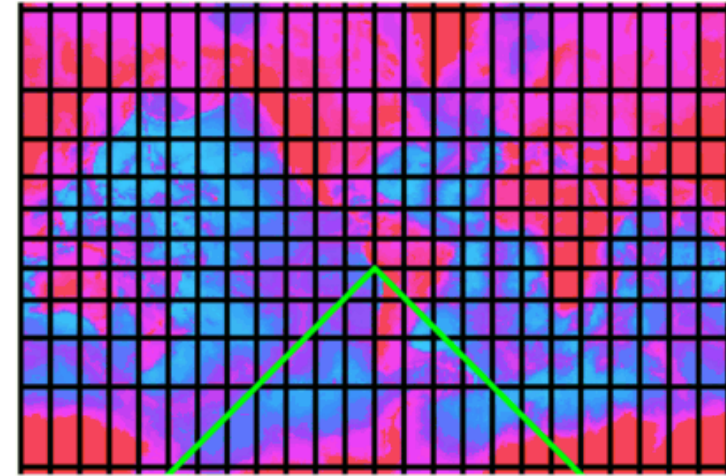
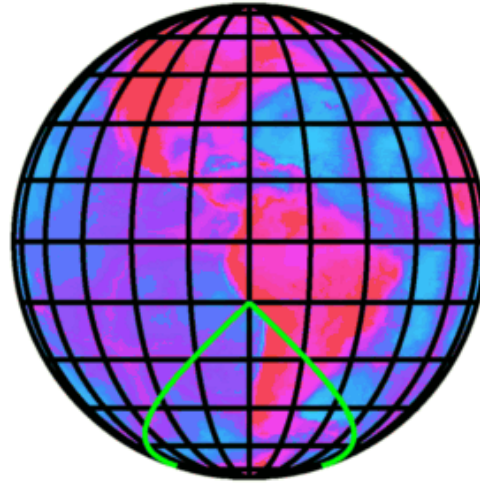

# The Balloon Analogy

- Notes that the galaxies DO NOT expand!
- The number density of galaxies goes down.
- The number density of photons goes down.
- The photon energy goes down.

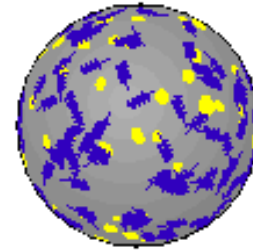



# Glue coins to the balloon





# CMB Anisotropy

**THE  TIMES**

25 April 1992

Prof. Stephen Hawking of Cambridge University, not usually noted for overstatement, said: “It is the discovery of the century, if not of all time.” – What a blurb!

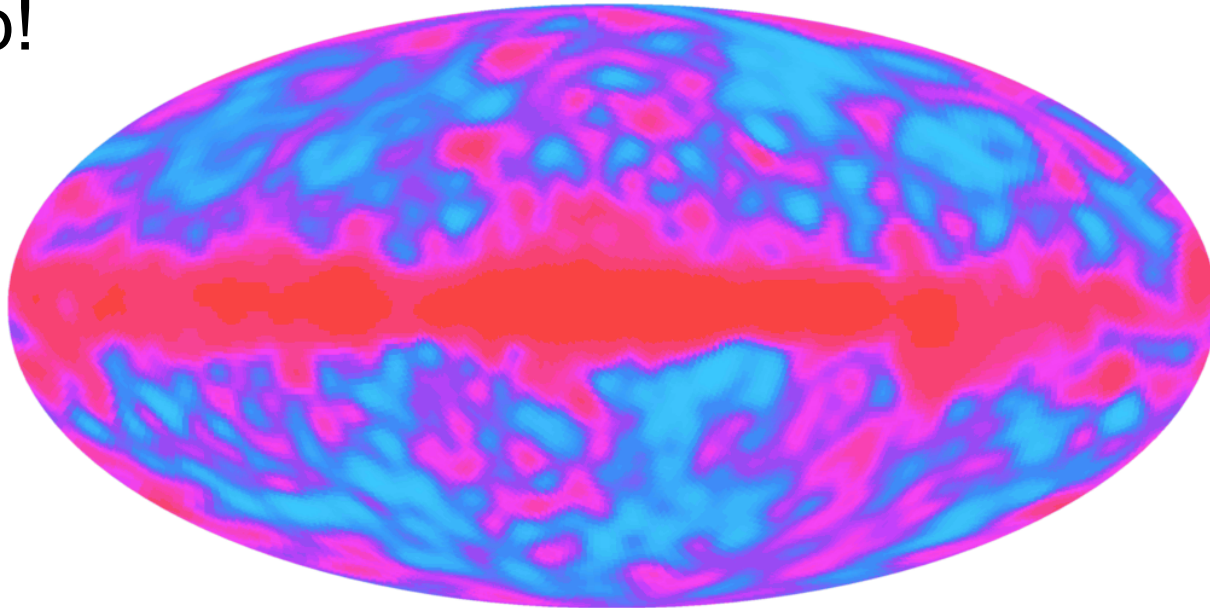

# The Red/Blue oval is a map made by COBE

- It does not mean the Universe is oval-shaped.
- COBE is the Cosmic Background Explorer, launched by NASA in 1989 to study the Cosmic Microwave Background discovered in 1965.

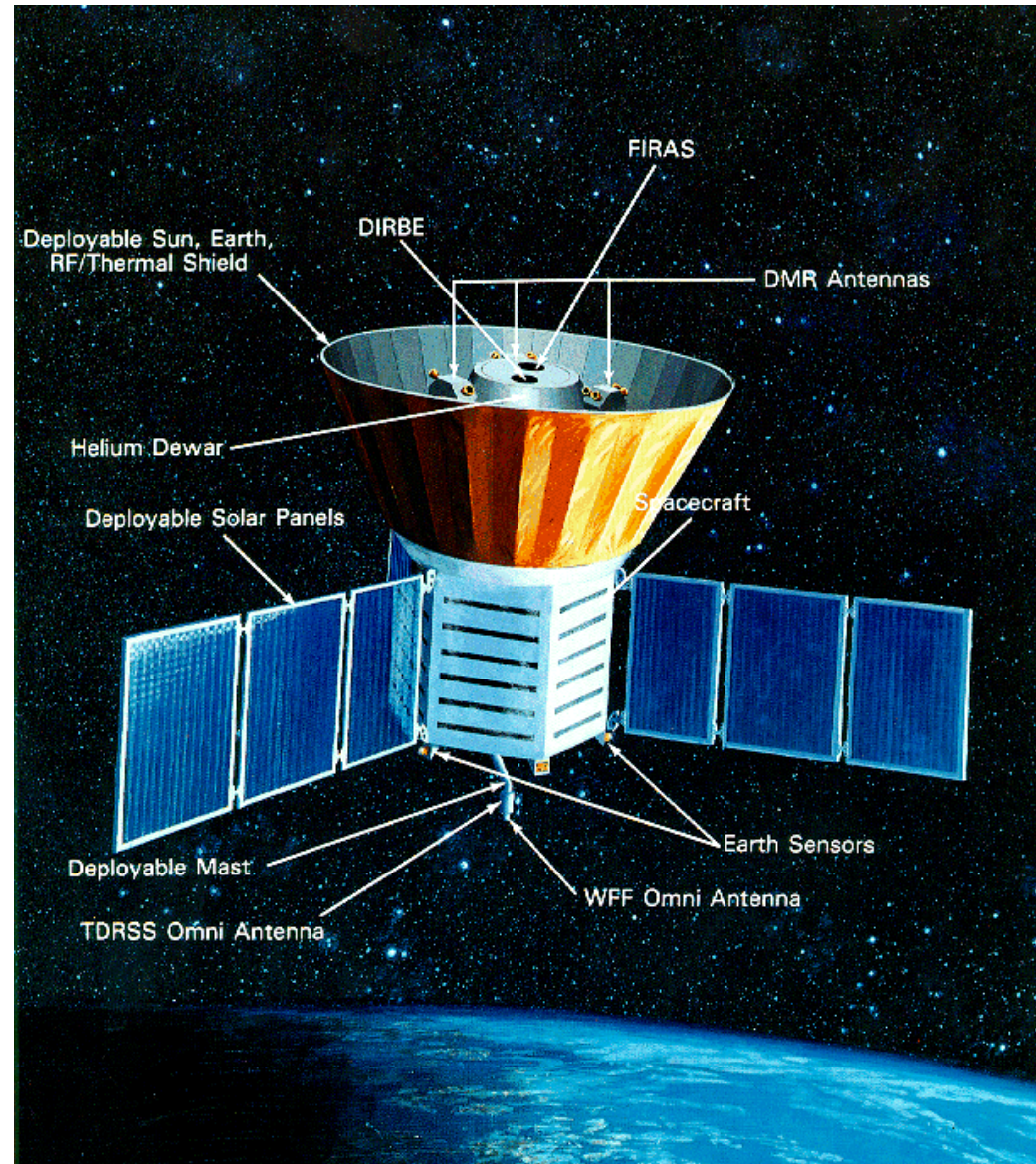

# COBE Science Working Group





# An equal area projection:

## EARTH

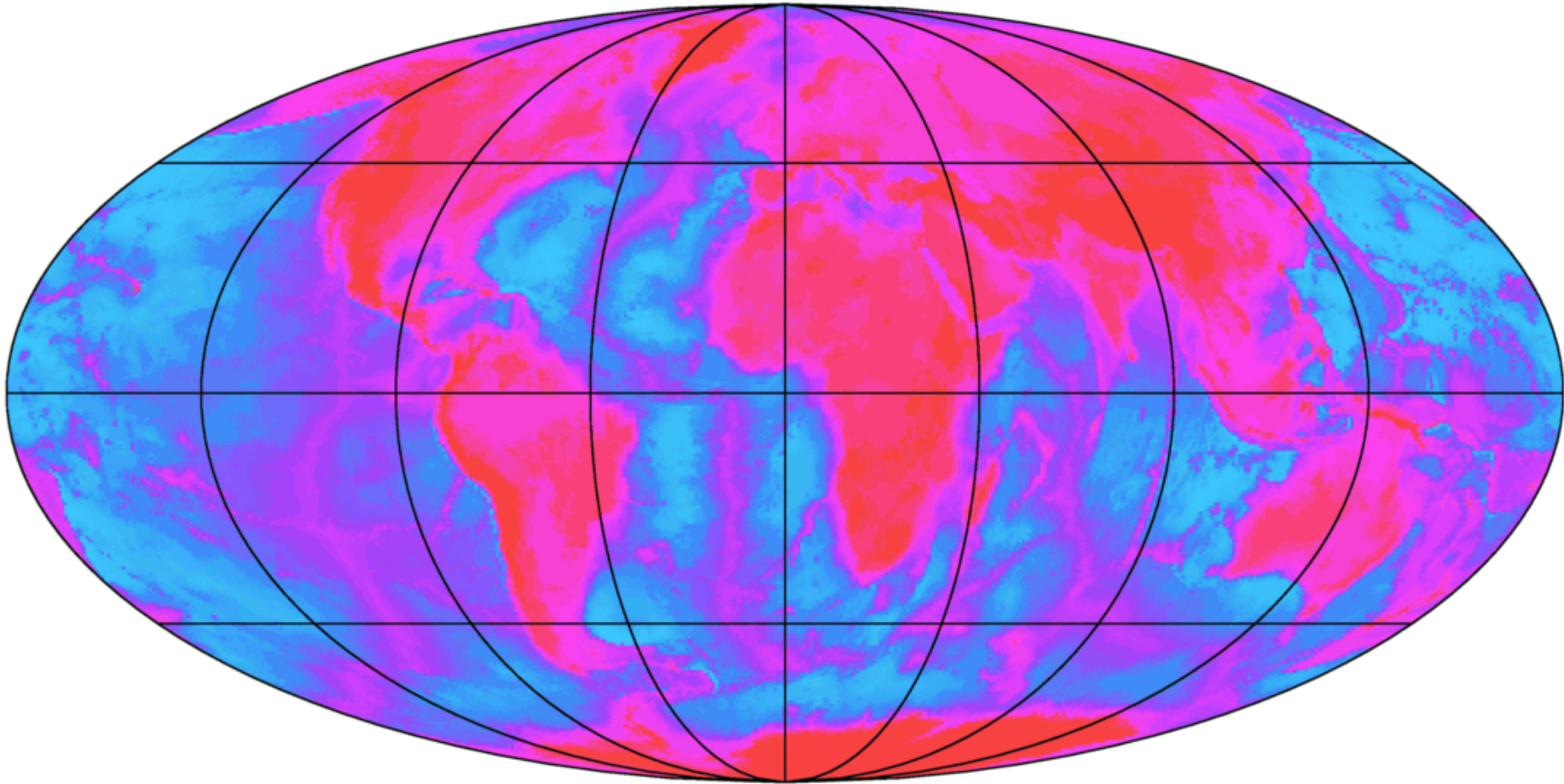

The oval is an all-sky map in galactic coordinates:

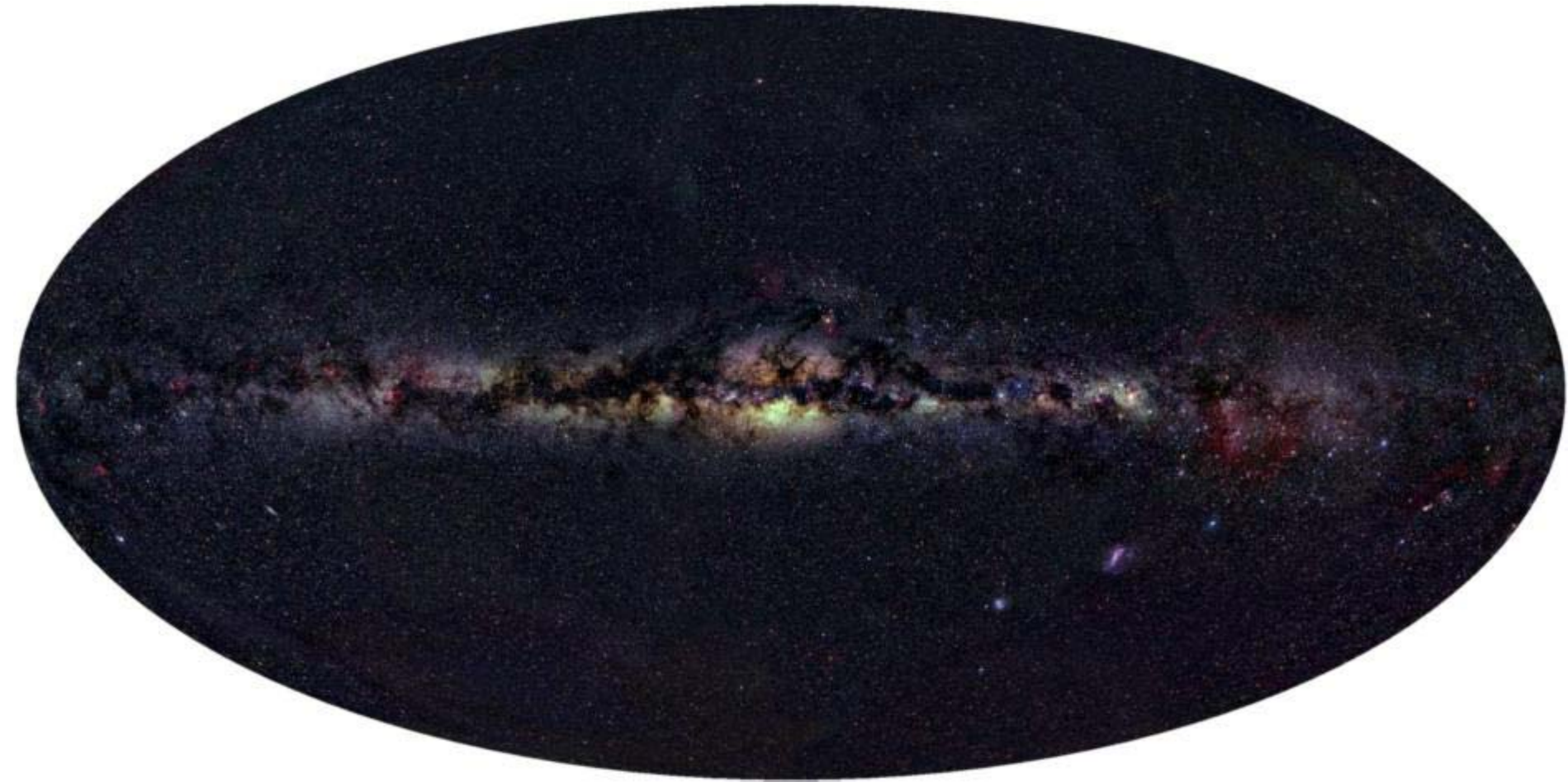

# Color Means Temperature

- Red areas are 30  $\mu\text{K}$  hotter than average and the blue areas are 30  $\mu\text{K}$  colder than average.
- As on the Earth map, color also maps into gravitational potential, with **red=high** and **blue=low**.

# Source of Cosmological Constant

- Quantum fluctuations could lead to a vacuum energy density.
- A vacuum energy density is equivalent to Einstein's cosmological constant:  $\Lambda$

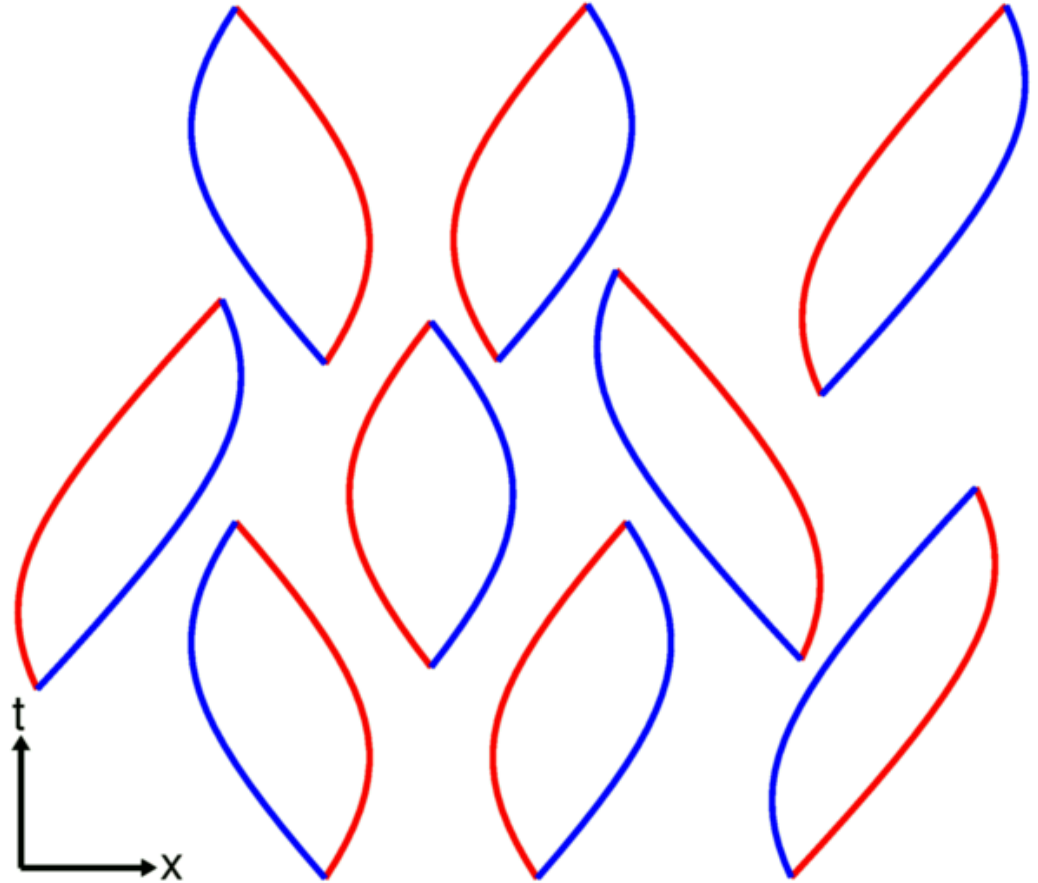

# Einstein's Static Universe

- Einstein used  $\Lambda$  to give a static Universe since in 1917 the Hubble law was not yet known.
- But a static Universe filled with light-emitting stars cannot be static. It will fill up with photons and gradually get brighter.
- Einstein's static model will fill up with light until the night sky is as bright as the surface of a star – Olbers paradox.
- Expanding de Sitter & Friedmann models are consistent with a dark night sky.



# So $\Lambda$ Was Neglected

- Expanding models with or without  $\Lambda$  are possible.
- $\Lambda$  was not needed and it was deprecated.

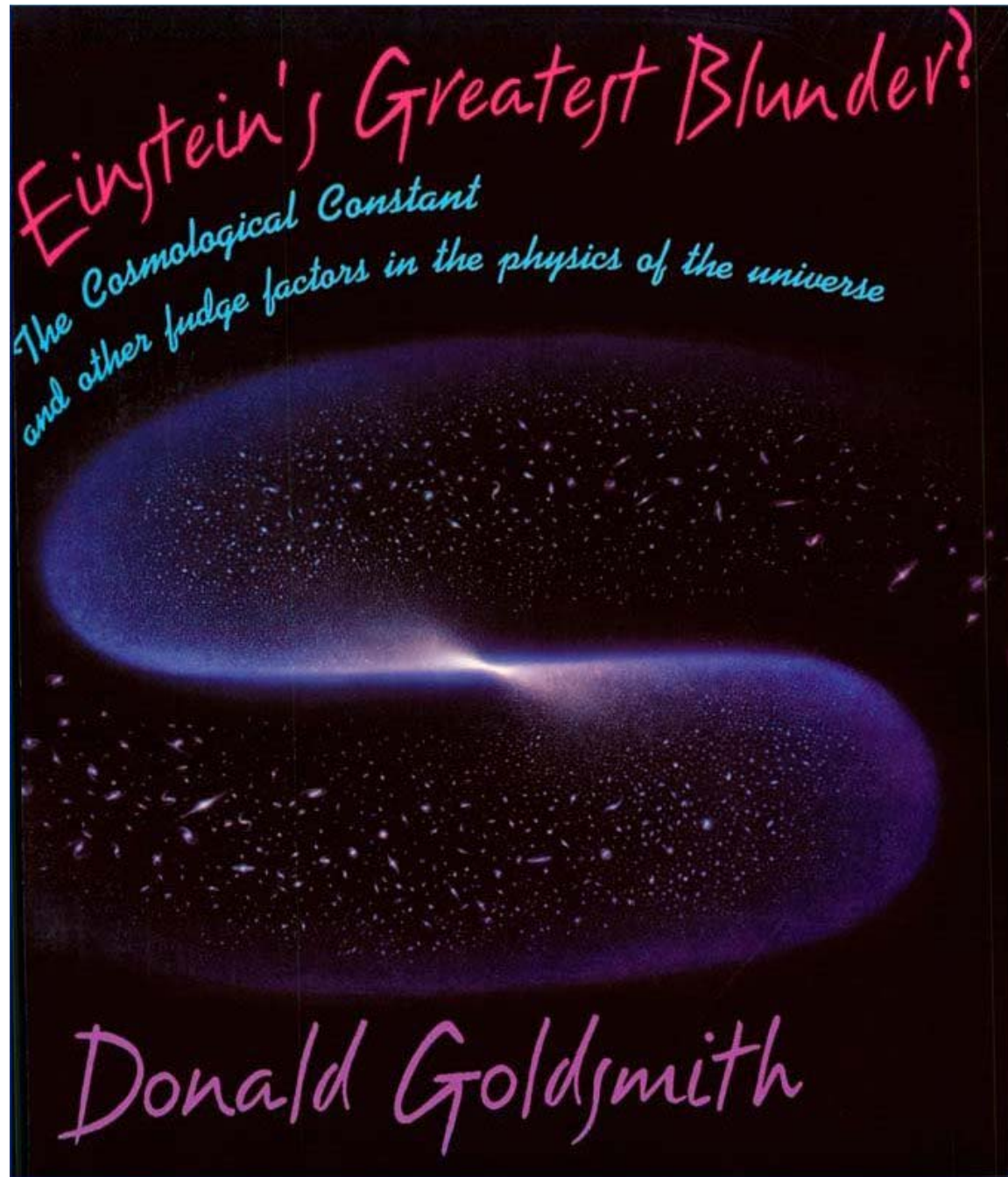

# $\Lambda$ has a repulsive effect

- In General Relativity energy has gravitational effects.
- A pressurized volume has energy,  $PV$ .
- Vacuum energy density must have a negative pressure.
- Net gravity from positive vacuum energy density plus negative pressure is repulsive.
- $\Lambda$  is part of the *inflationary scenario*:
  - $\Lambda$  causes a rapid exponential expansion of the Universe called *inflation* that occurred during the first picosecond after the Big Bang. Then this  $\Lambda$  disappeared in a phase transition.

# Animated View of Inflation

- Quantum fluctuations occur uniformly throughout space-time
- Future light cones expand exponentially.
- Pattern has equal coverage in big circles, medium circles and small circles: *equal power on all scales.*

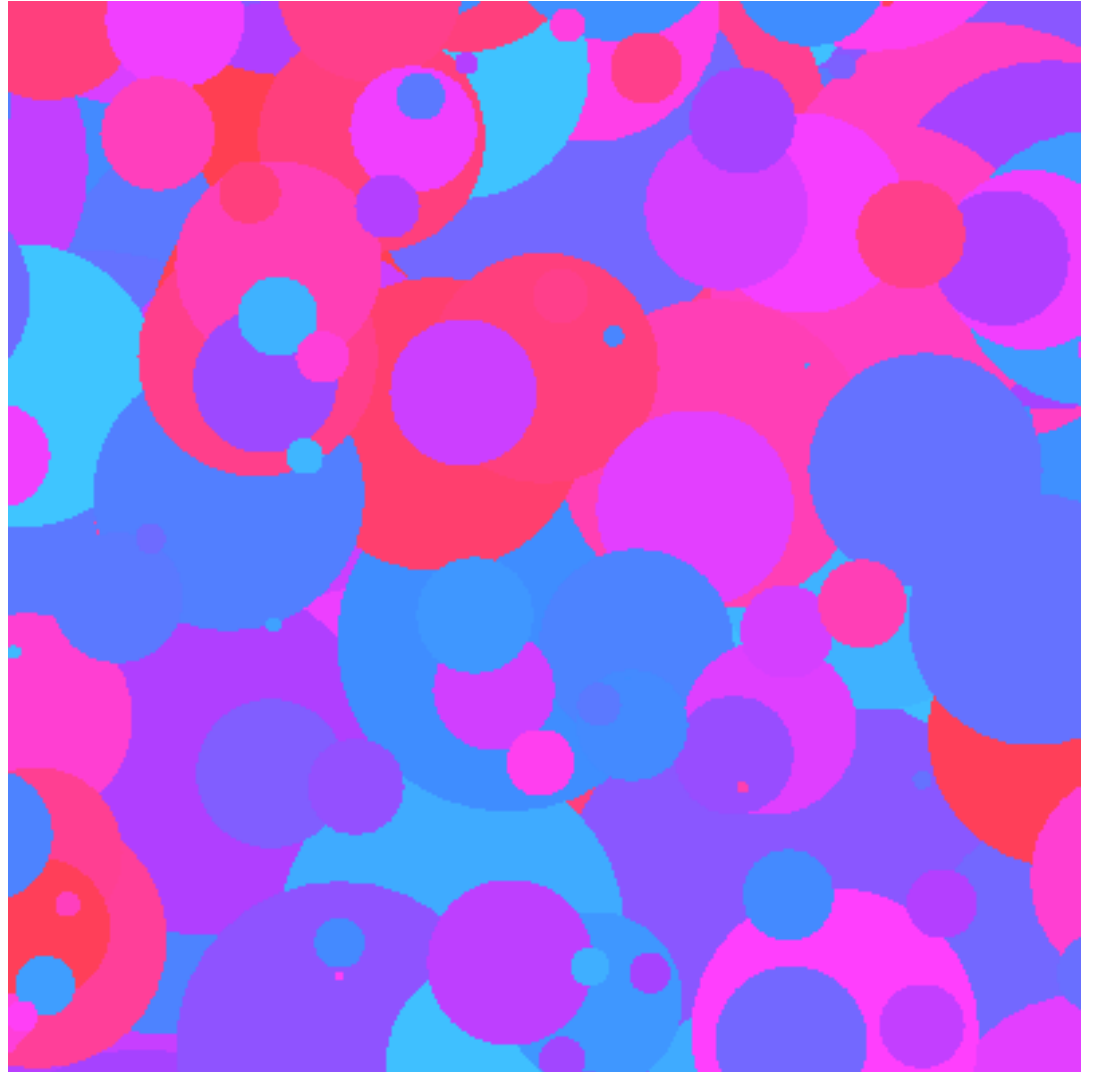



# COBE Differential Microwave Radiometers

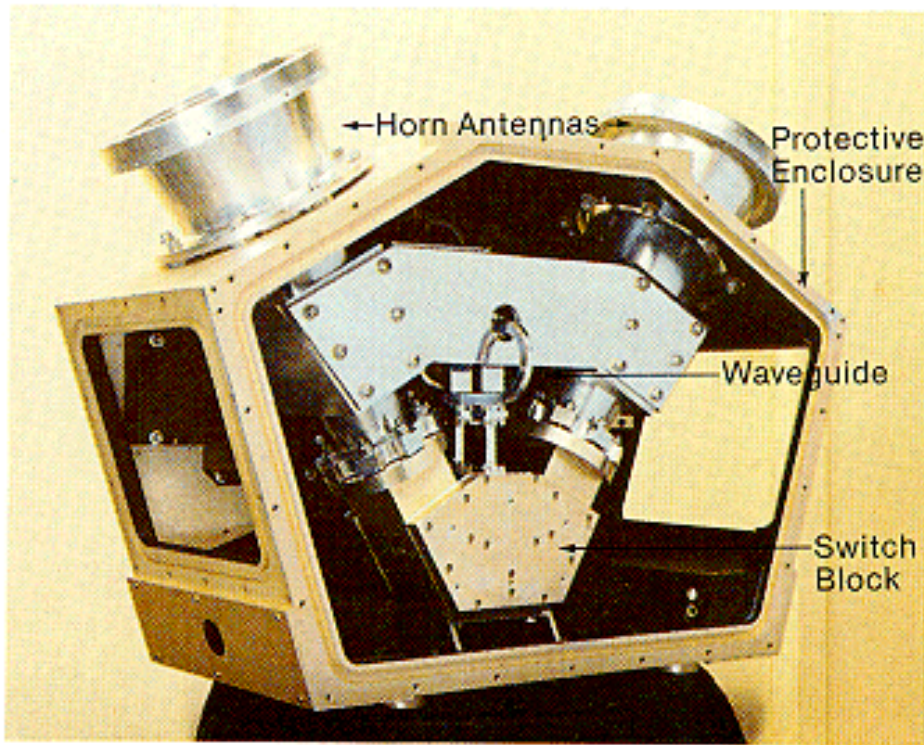

*The 9.6 mm DMR receiver partially assembled.  
Corrugated cones are antennas.*

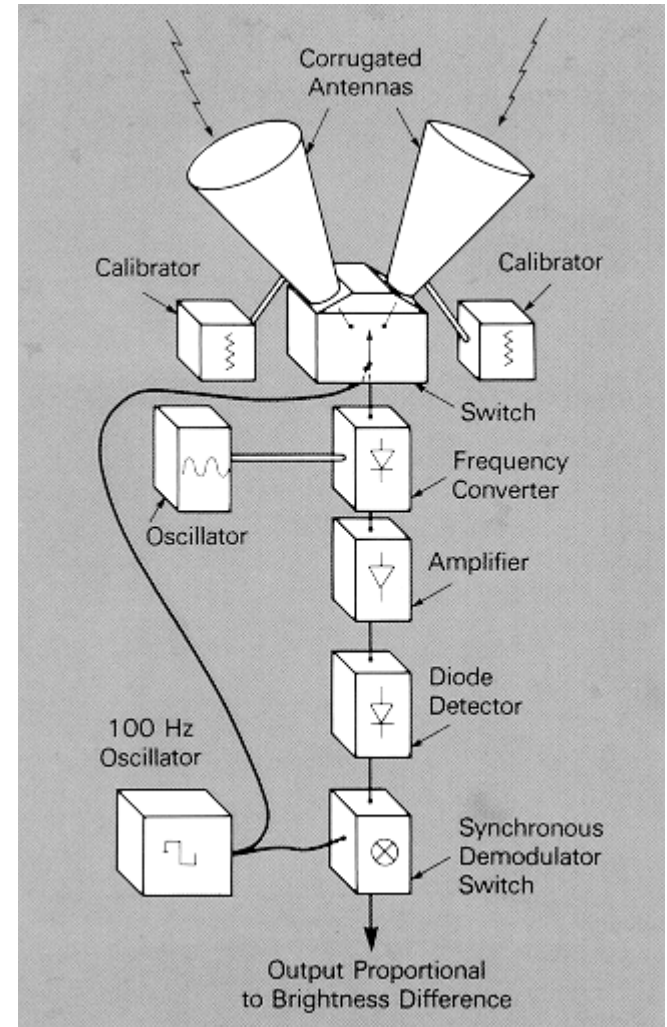

# COBE DMR vs EPAS

COBE Data

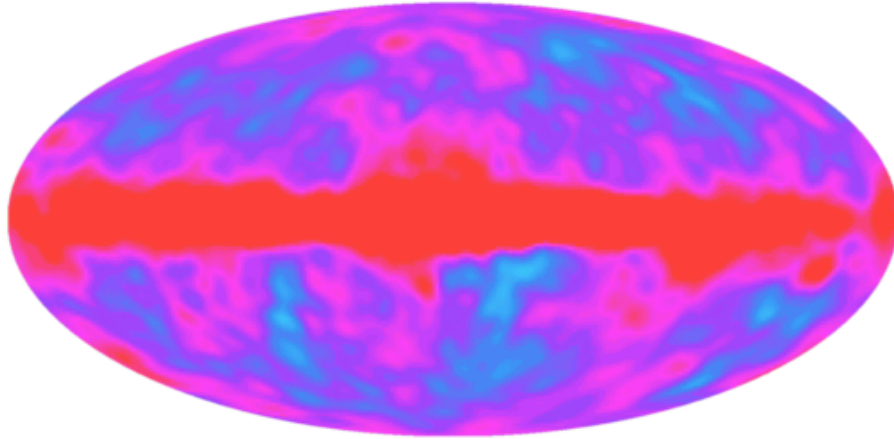

Equal Power on All Scales Model

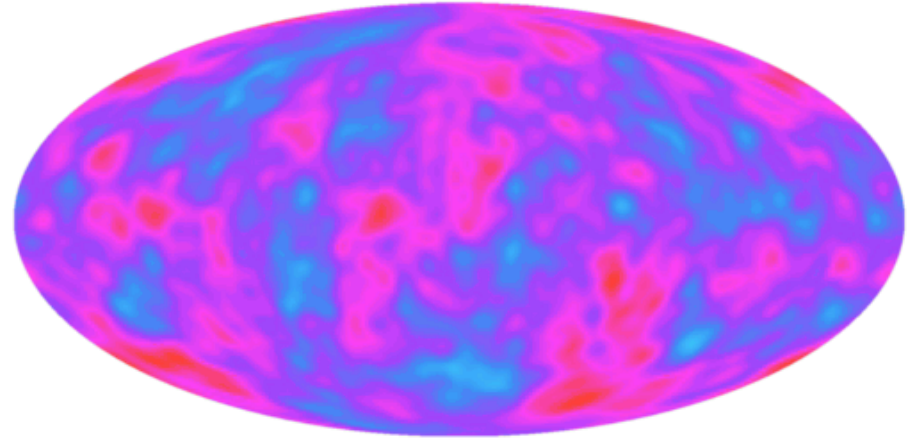

COBE found that the “Equal Power on All Scales” prediction of inflation is correct. Hence Hawking’s excitement.

# Two Fluids in the Early Universe

- Most of the mass is dark matter
  - 80-90% of the density
  - Zero pressure
  - Sound speed is zero
- The baryon-photon fluid
  - baryons are protons & neutrons = all ordinary matter
  - energy density of the photons is bigger than  $c^2$  times the mass density of baryons
  - Pressure of photons =  $u/3 = (1/3)\rho c^2$
  - Sound speed is about  $c/\sqrt{3} = 170,000$  km/sec

Traveling Sound Wave:  $c_s = c/\sqrt{3}$

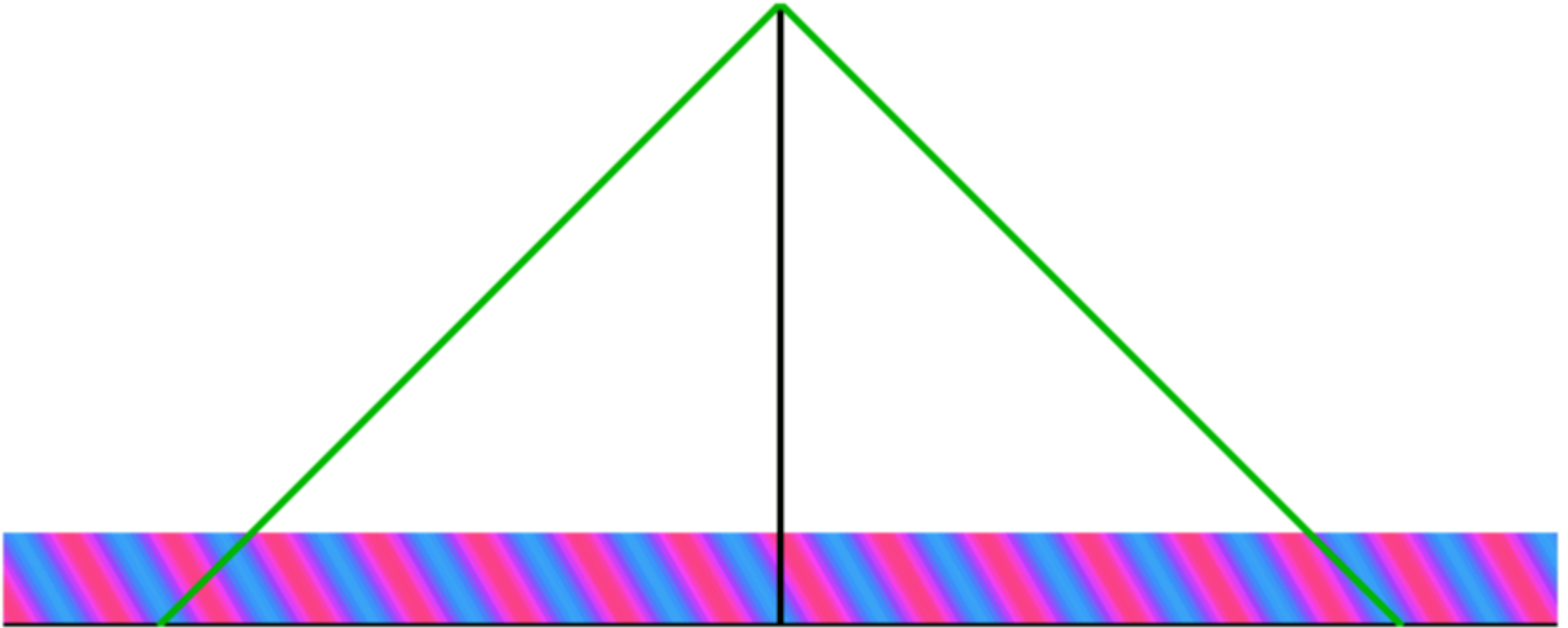

# Stay at home Dark Matter

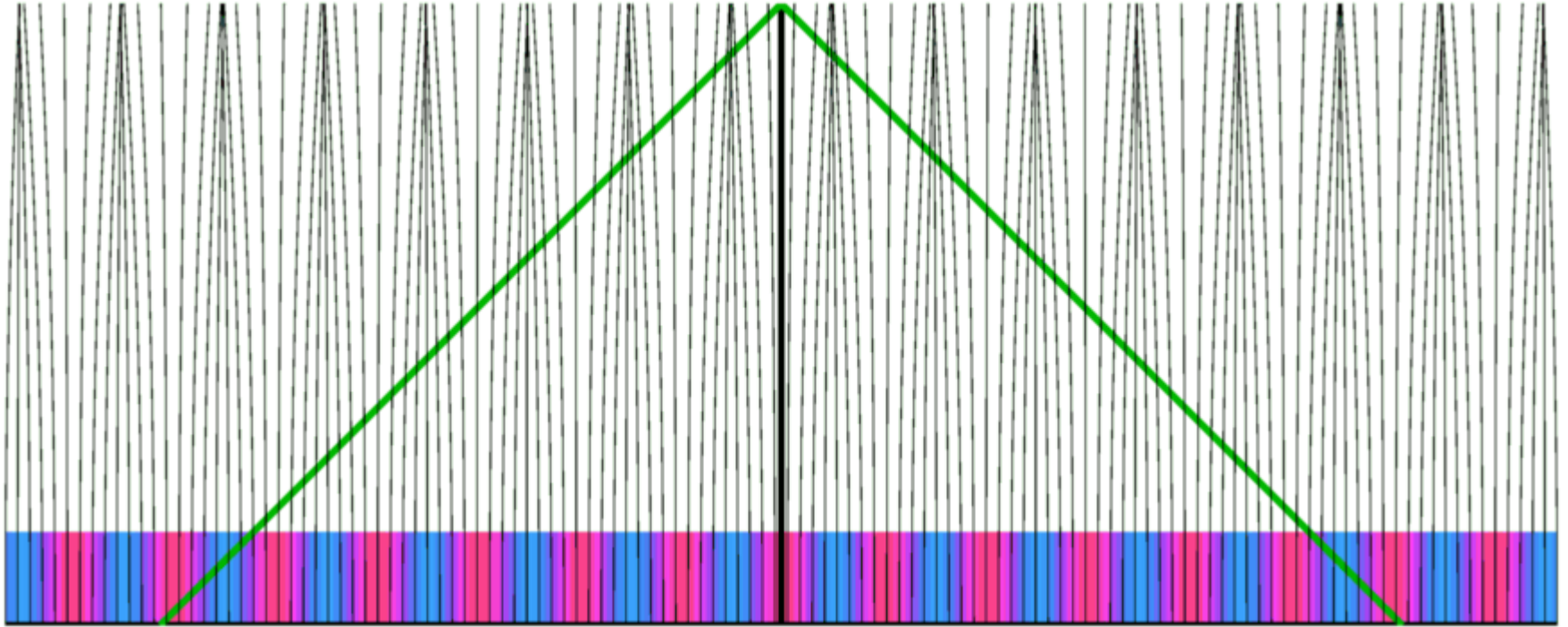



# Interference at last scattering

- For the wavelength illustrated [ $1/2$  period between the Big Bang and recombination], the denser = hotter effect and potential well = cooler effect have gotten in phase.
- For larger wavelengths they are still out of phase at recombination.

# Spherical Harmonic Decomposition

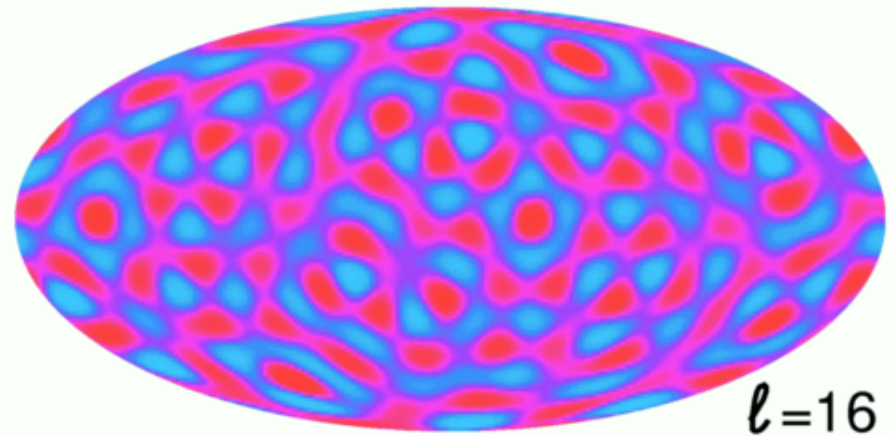
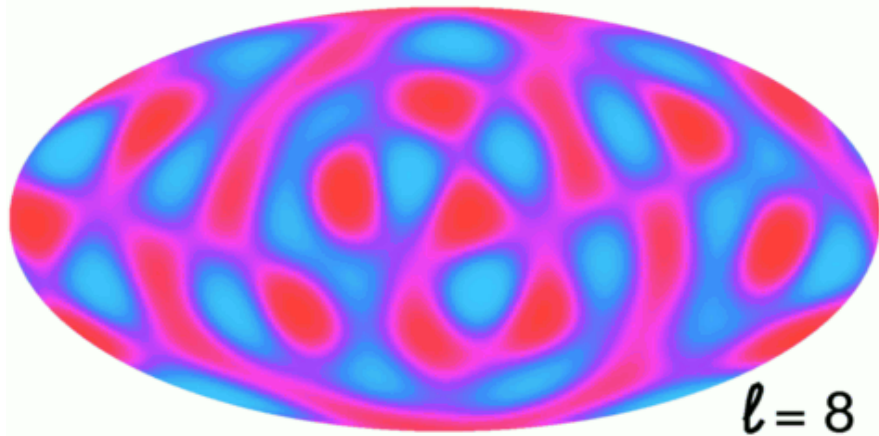
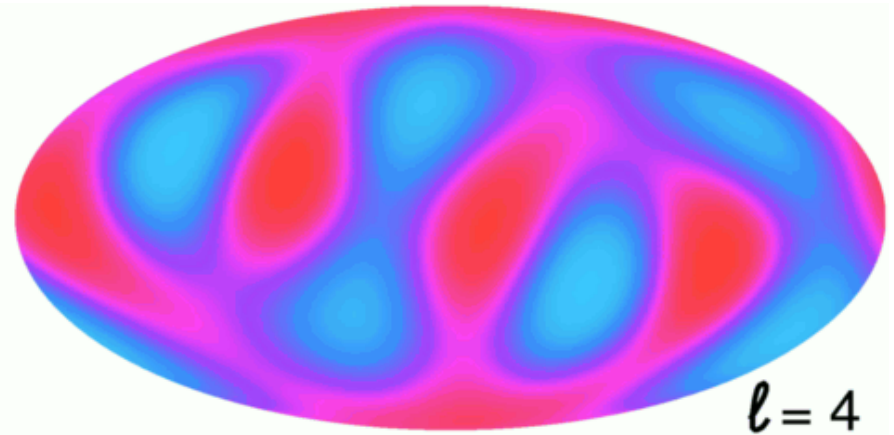
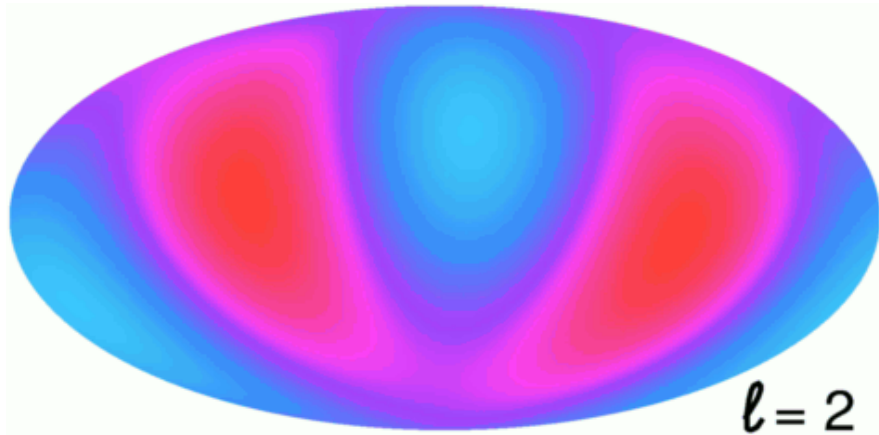

# Many parameters to measure

- Careful measurements of the power at various angular scales can determine the Hubble constant, the matter density, the baryon density, and the vacuum density.

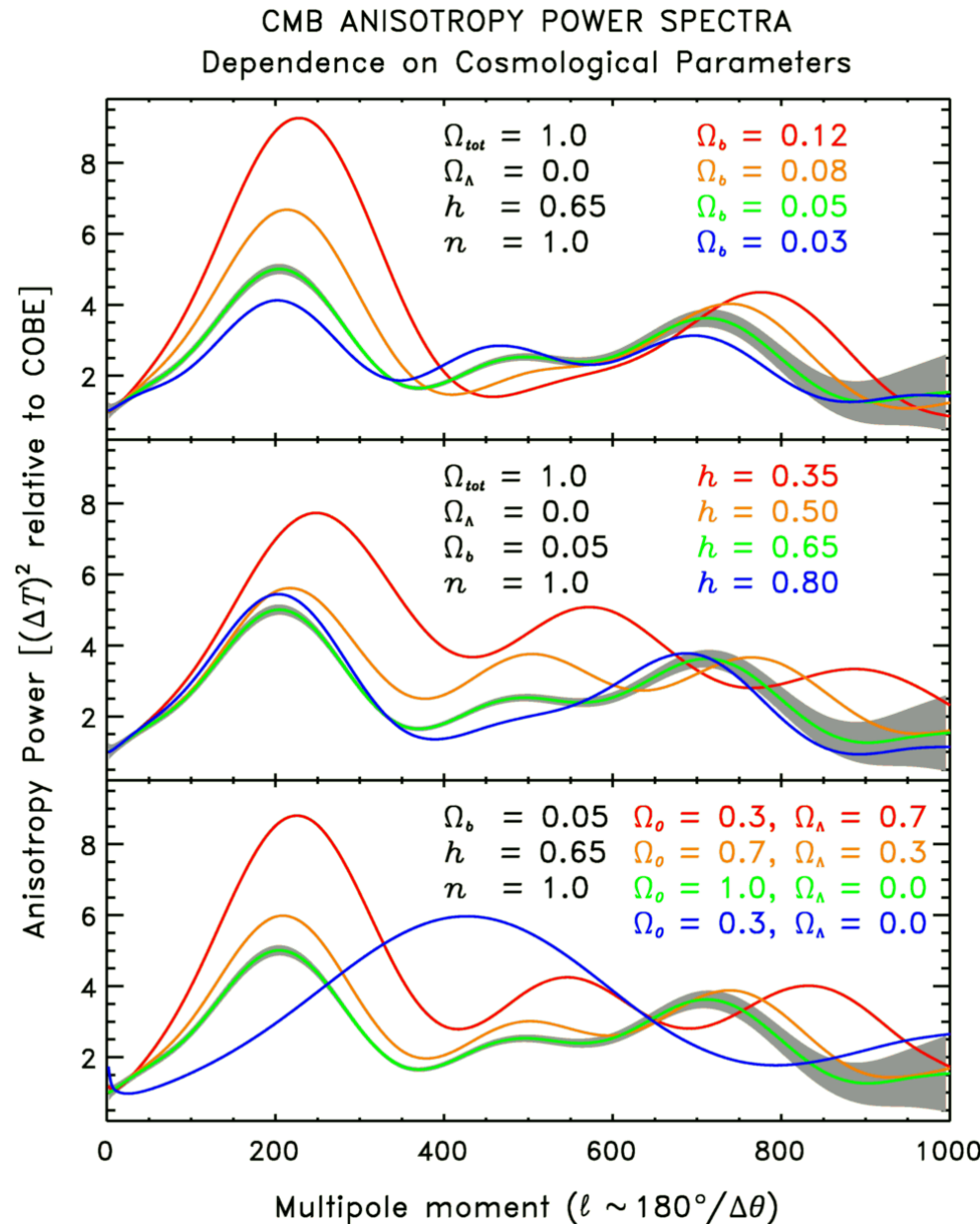

# COBE View was Blurry



Sometimes higher resolution...



reveals the secret of the Universe

# A New Cosmology Satellite

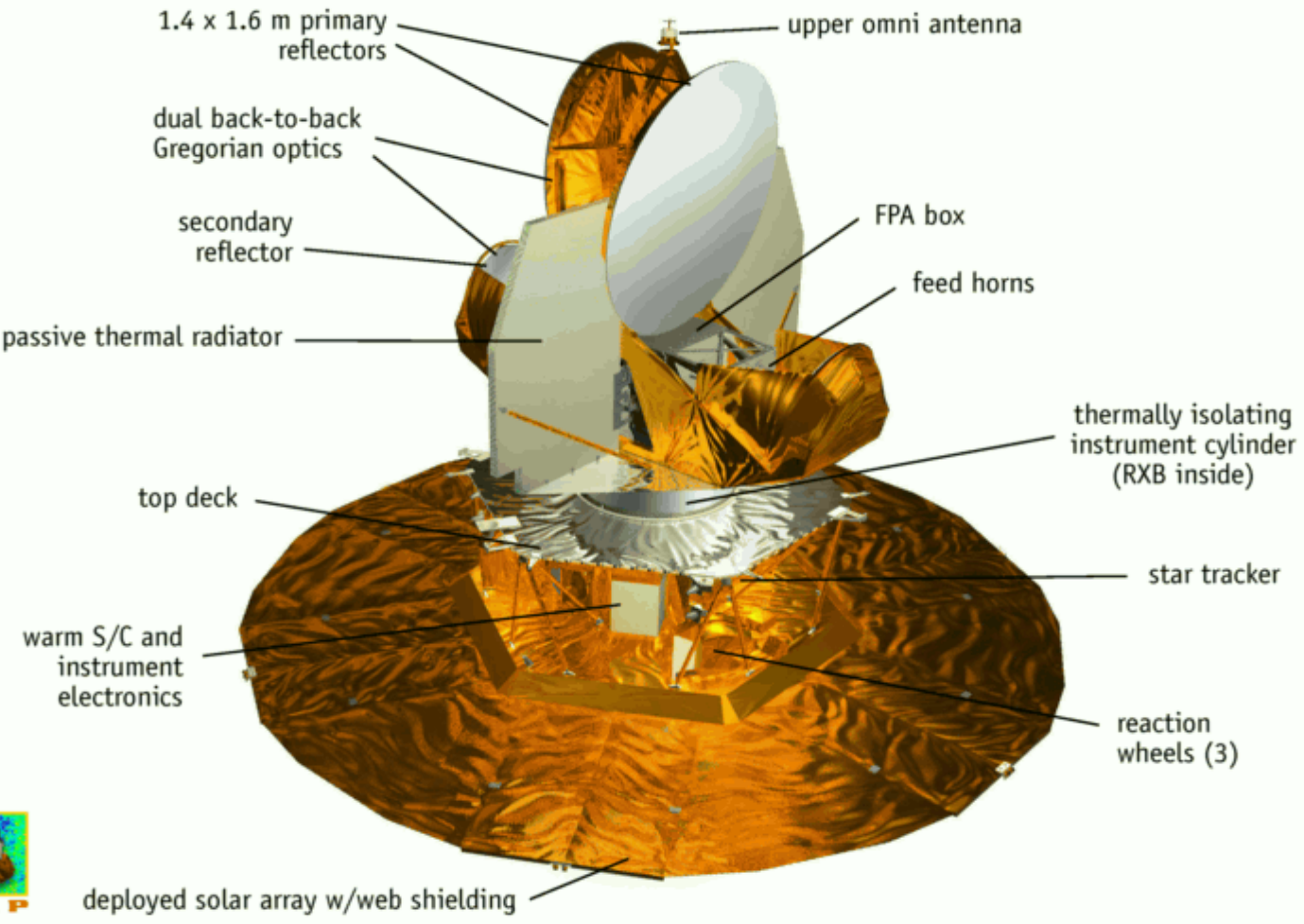



# WMAP Science Working Group



# WMAP Status on 30 Jun 2001



# and WMAP has a NED Controller!

## S/A Deployment NED Control

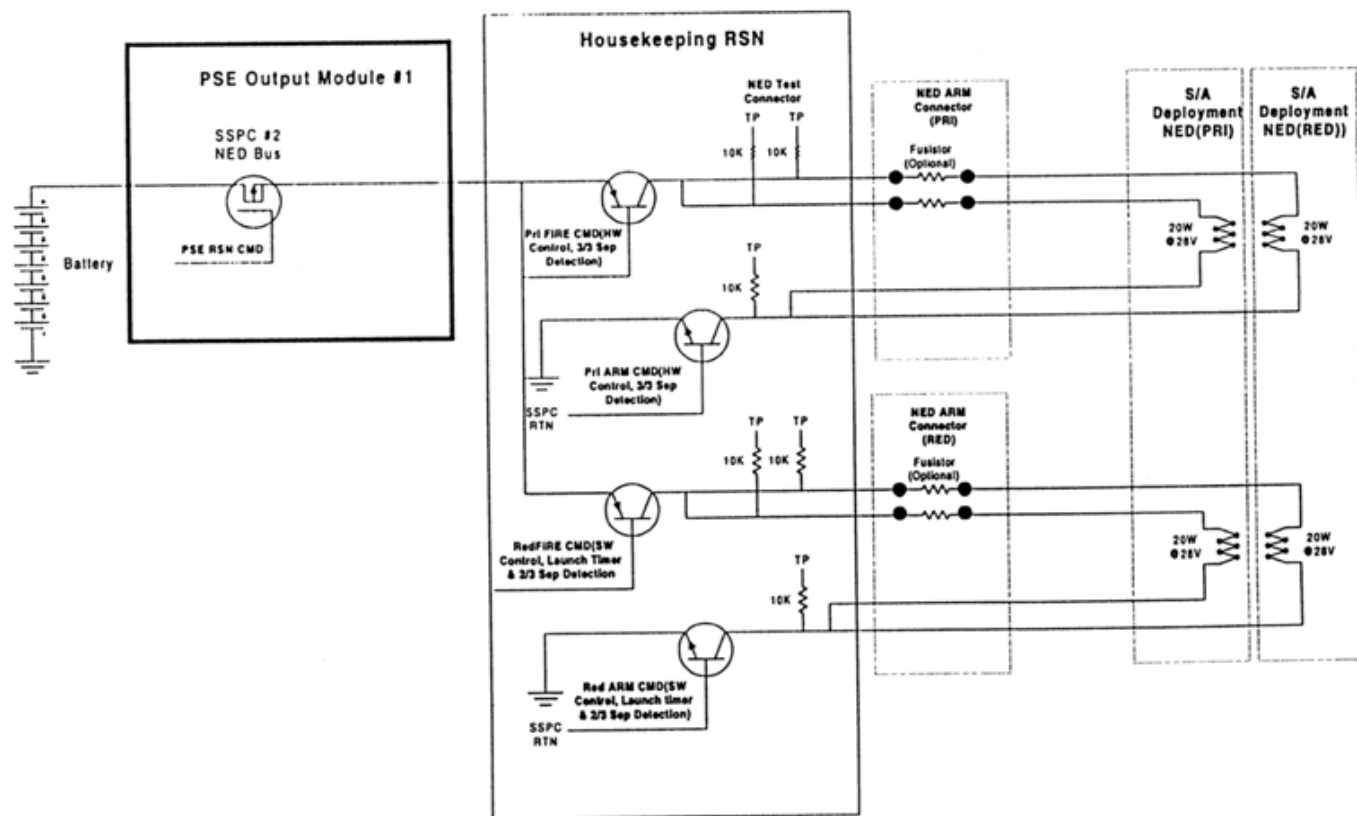



# QVW as RGB

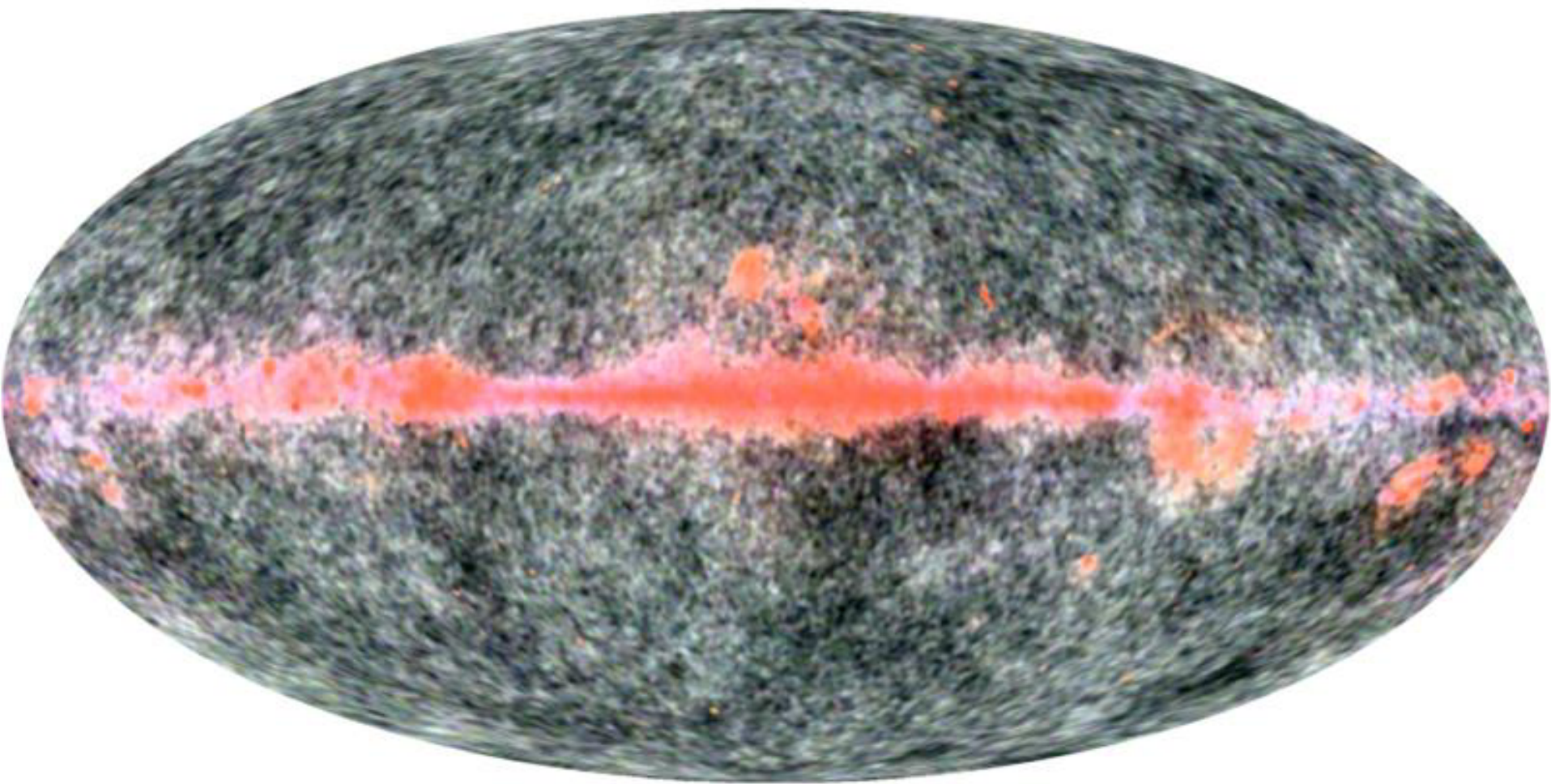

# Effects on Peak Position: $l_{pk}$

- + Open or vacuum dominated Universes give larger distance to last scattering surface
- + High matter density gives smaller wavelength

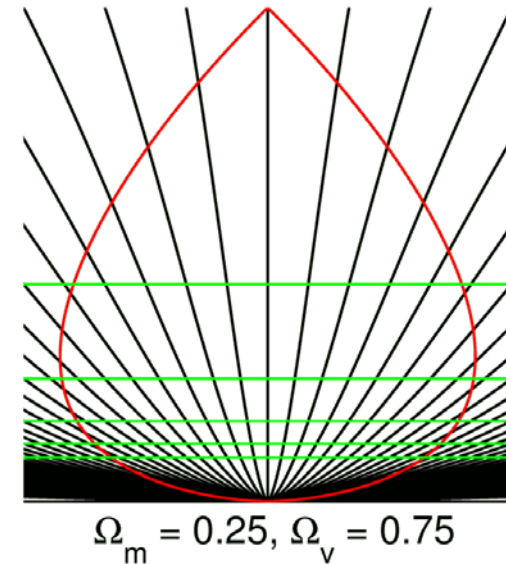
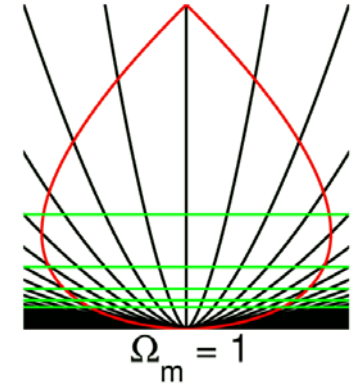
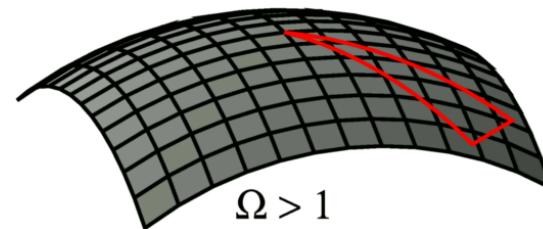
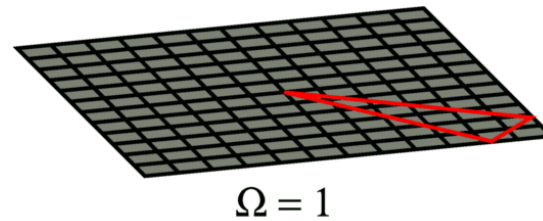
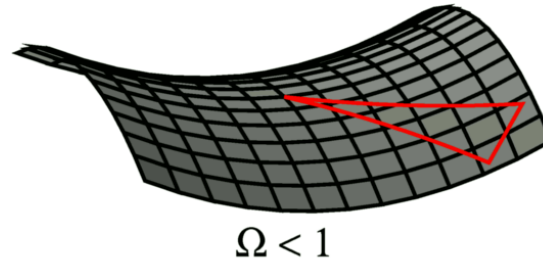

# Fiction: CMB implies a flat Universe

$H_0$ : 30 40 50 60 70 80 90 100

- The CMB fits any model from a flat  $\Lambda$ CDM model to a closed model with no vacuum energy. All data combined imply a flat Universe.

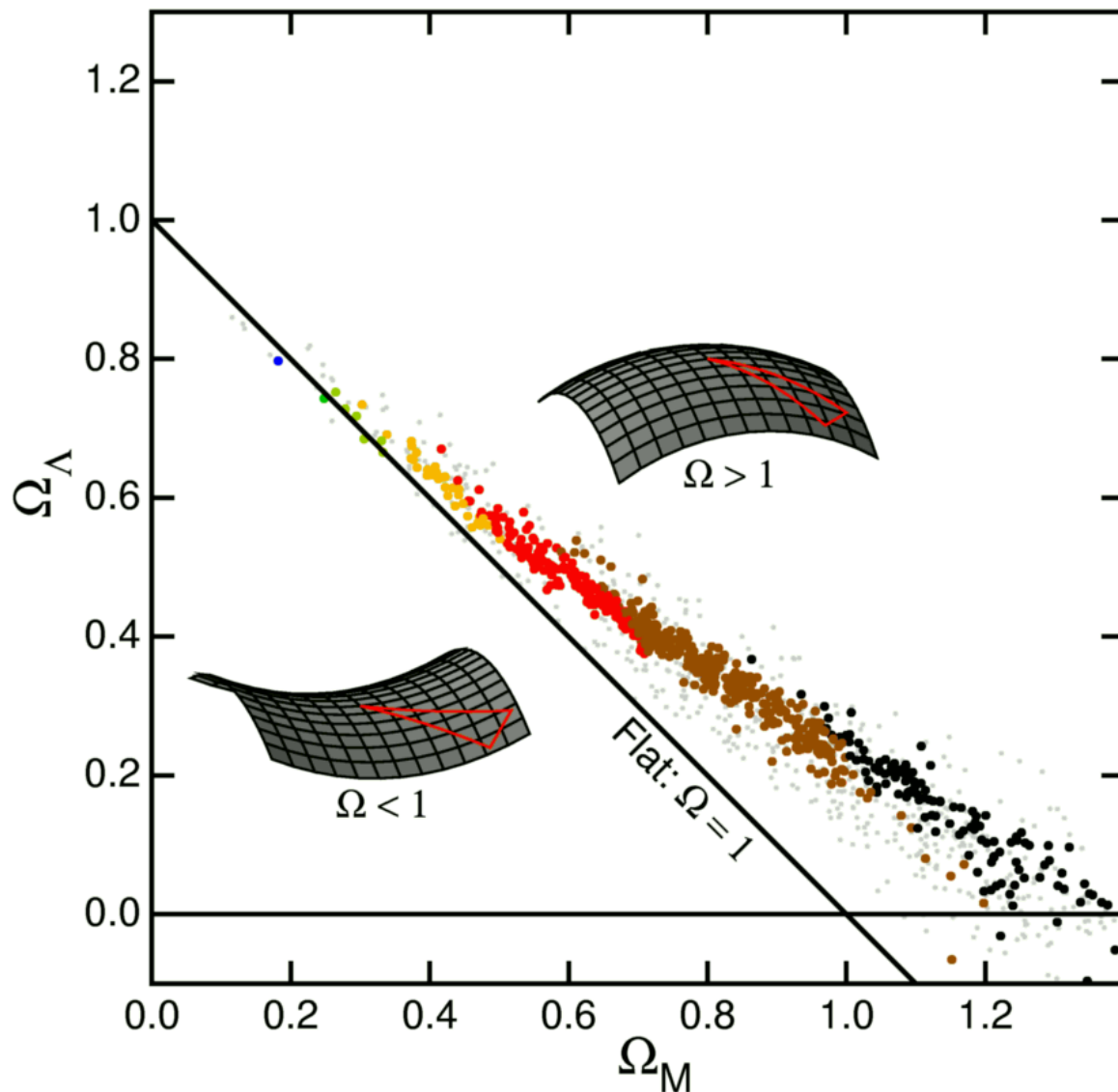

# Info from peak & trough heights

- Overall Amplitude of the perturbations
  - Agrees with large scale structure if almost all the dark matter is COLD dark matter
- Primordial power spectrum power law spectral index:  $n = 0.99 \pm 0.04$  without running index.
  - EPAS inflationary prediction is  $n = 1$
- Baryon/photon and DM/baryon density ratios
  - $\rho_b = 0.42 \text{ yoctograms/m}^3 = 0.42 \times 10^{-30} \text{ gm/cc}$
  - $\rho_{\text{cdm}} = 2.1 \text{ yg/m}^3$  [ $\omega \equiv \Omega h^2 = \rho / \{18.8 \text{ yg/m}^3\}$ ]

# Results With WMAP

Note the new  
BBNS value from  
astro-ph/0302006:

The baryon density  
from the D/H ratio  
produced during  
“The First Three  
Minutes” agrees  
with the baryon  
density from the  
CMB acoustic  
peaks produced  
380,000 years after  
the Big Bang.

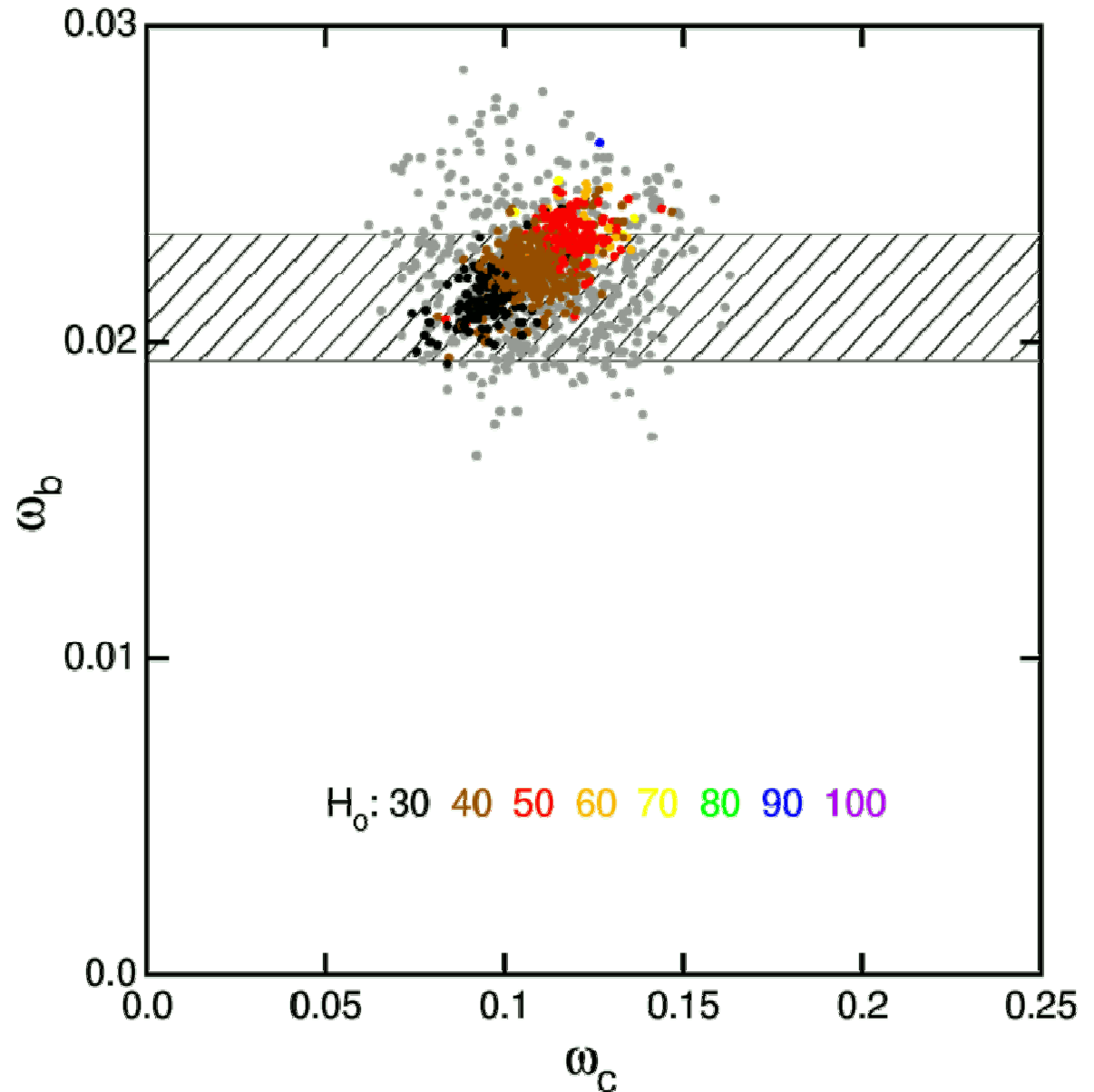

# $\Lambda$ CDM is a Good Fit

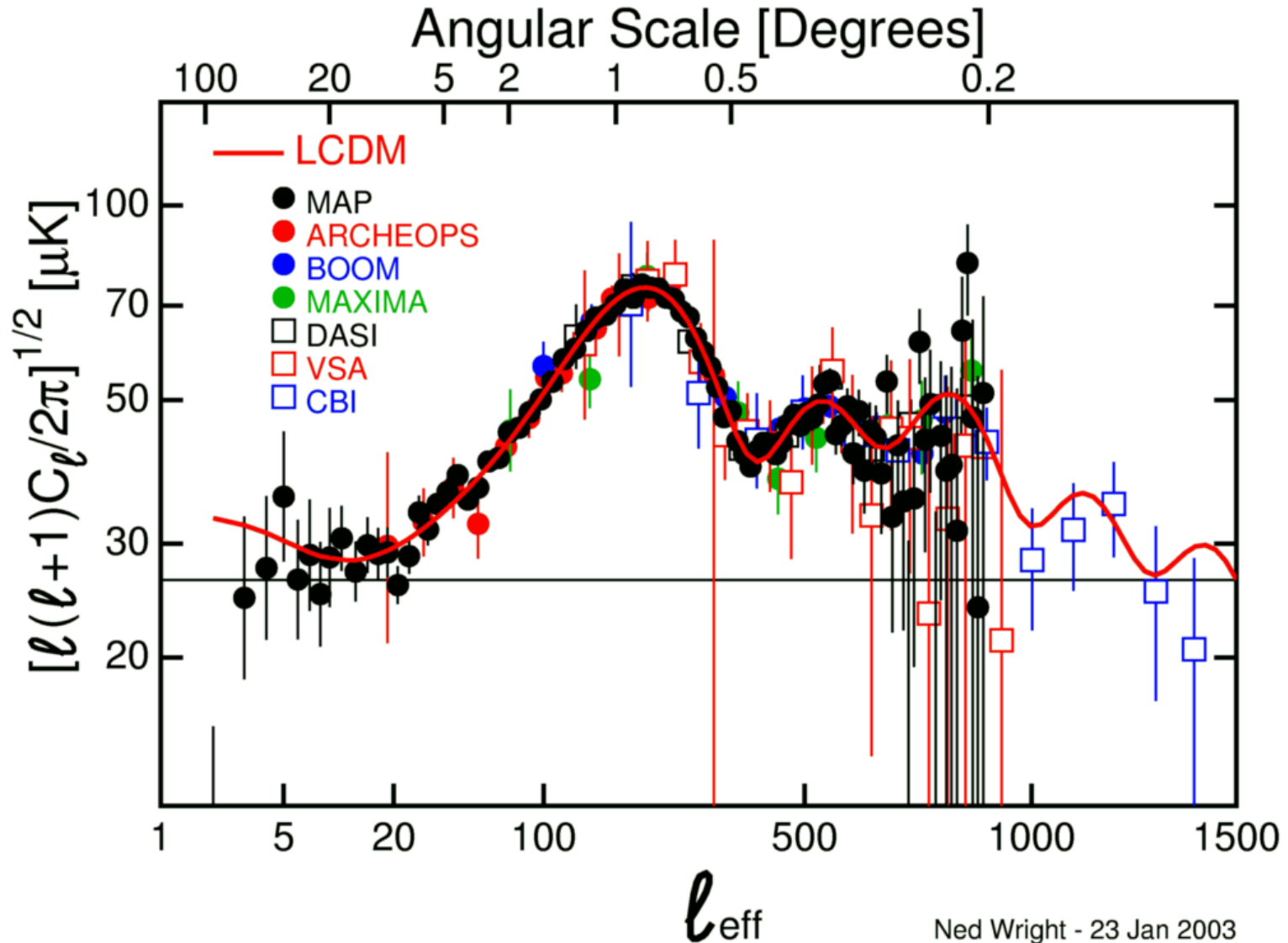

$$H_0 = 71, \Omega_\Lambda = 0.73, \Omega_b h^2 = 0.0224, \Omega_m h^2 = 0.135, \Omega_{\text{tot}} = 1$$



# Accelerating Universe: 1998

Distant (high  $z$ ) supernovae fainter than expected.

This was the AAAS discovery of the year in 1998.

$\Lambda$  causes acceleration!

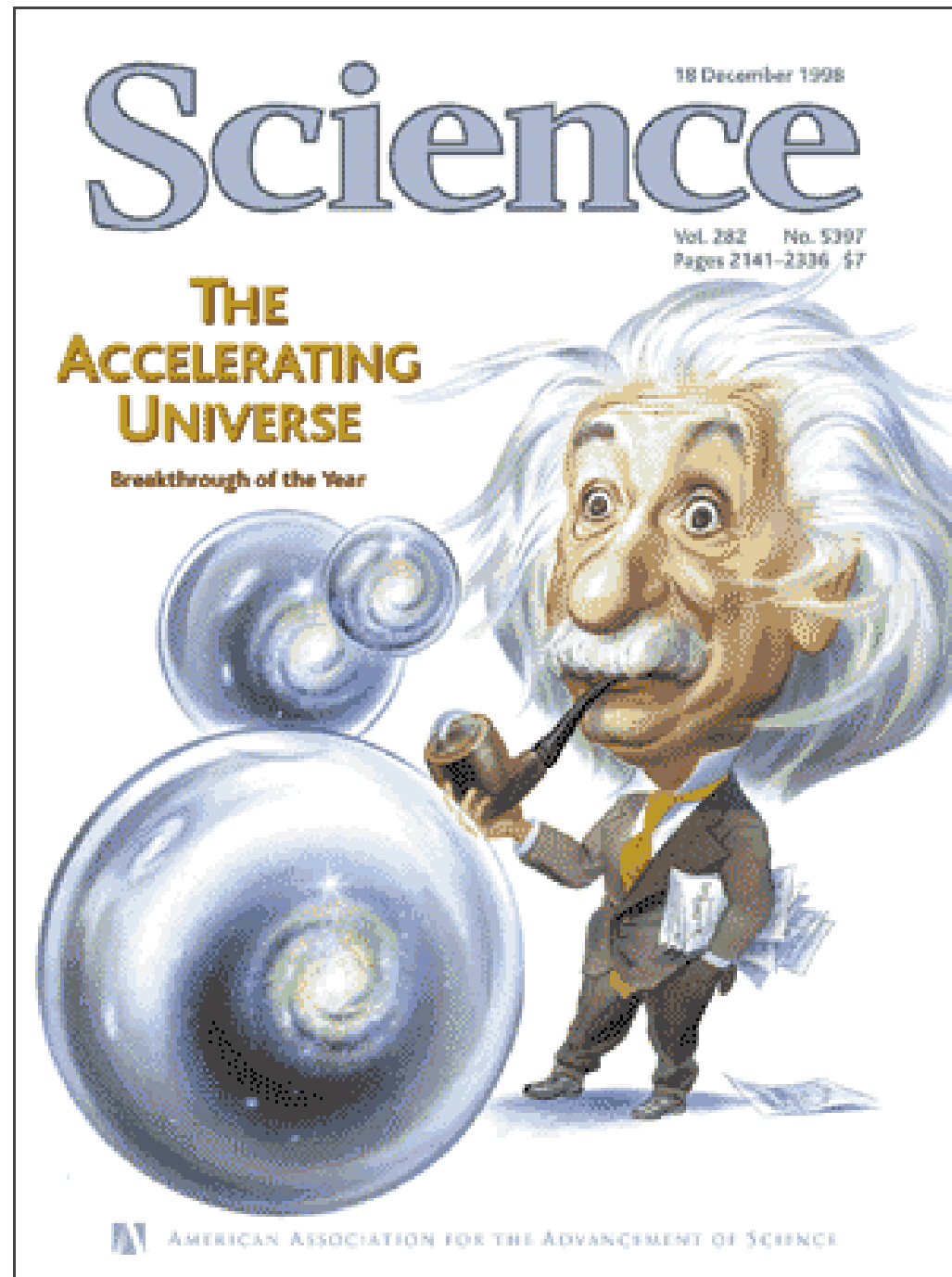



# What is a supernova?

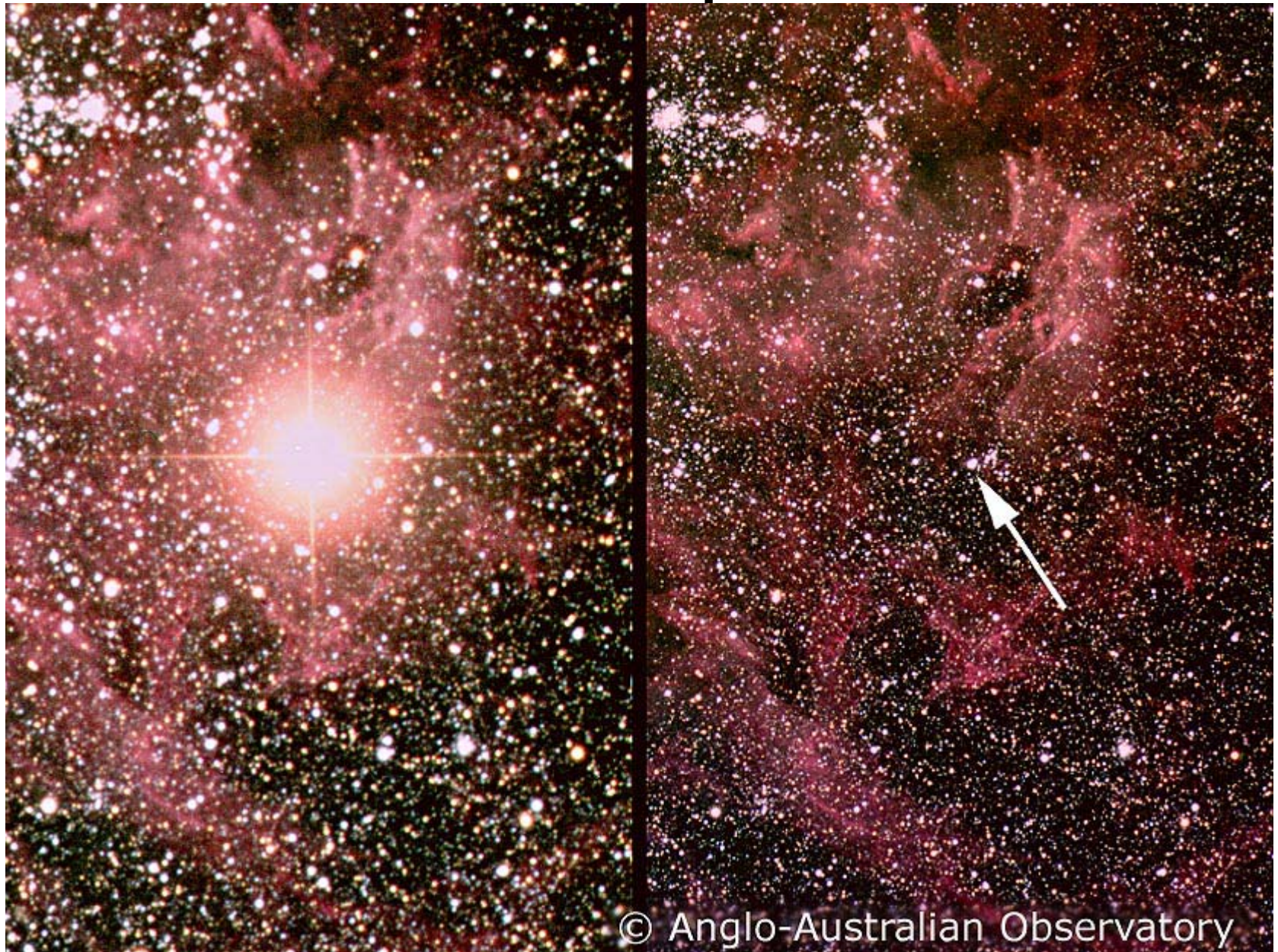



We recently learned how to read the “wattage” label on supernovae:

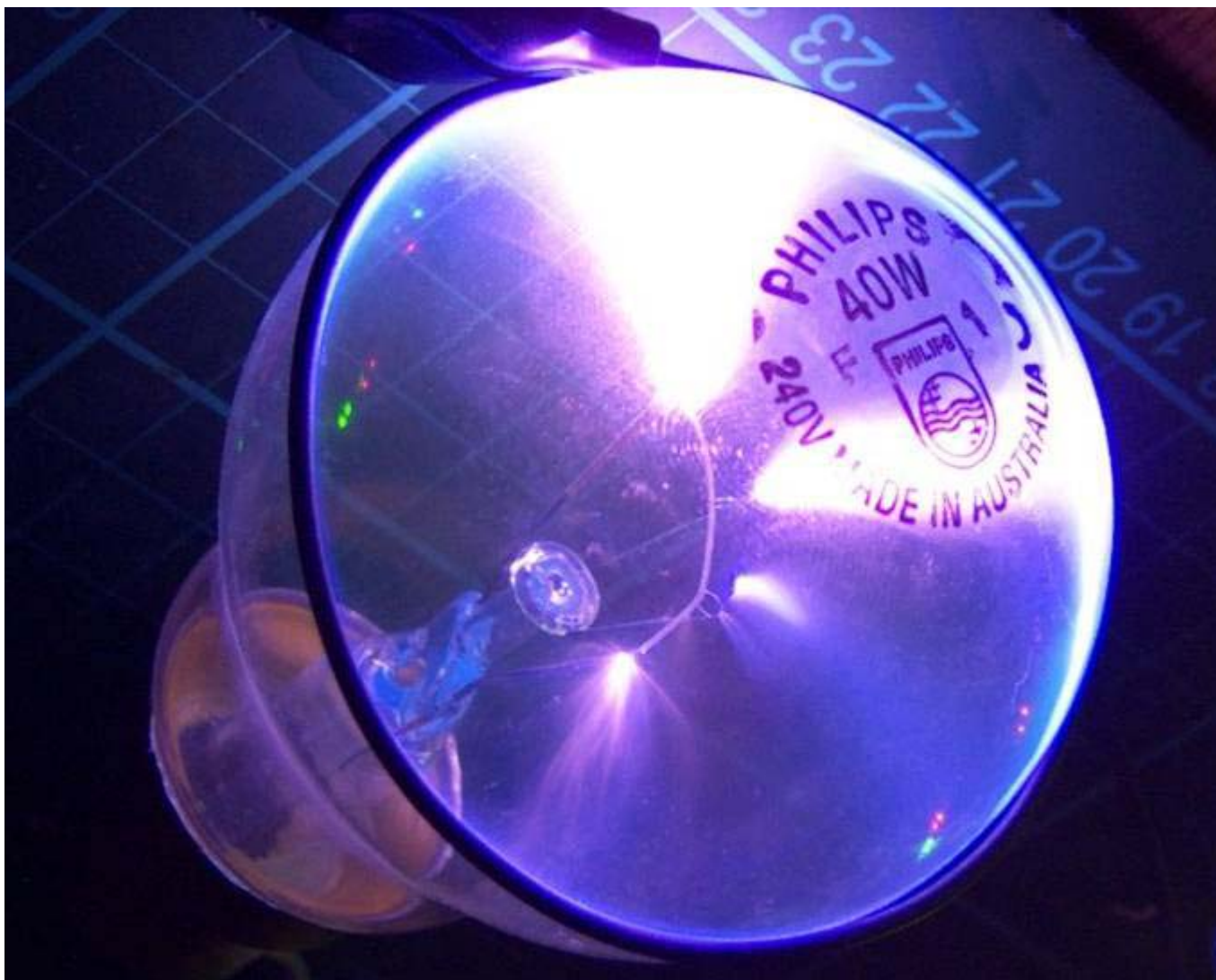

As a result, data on velocity vs distance is now much better! 1929

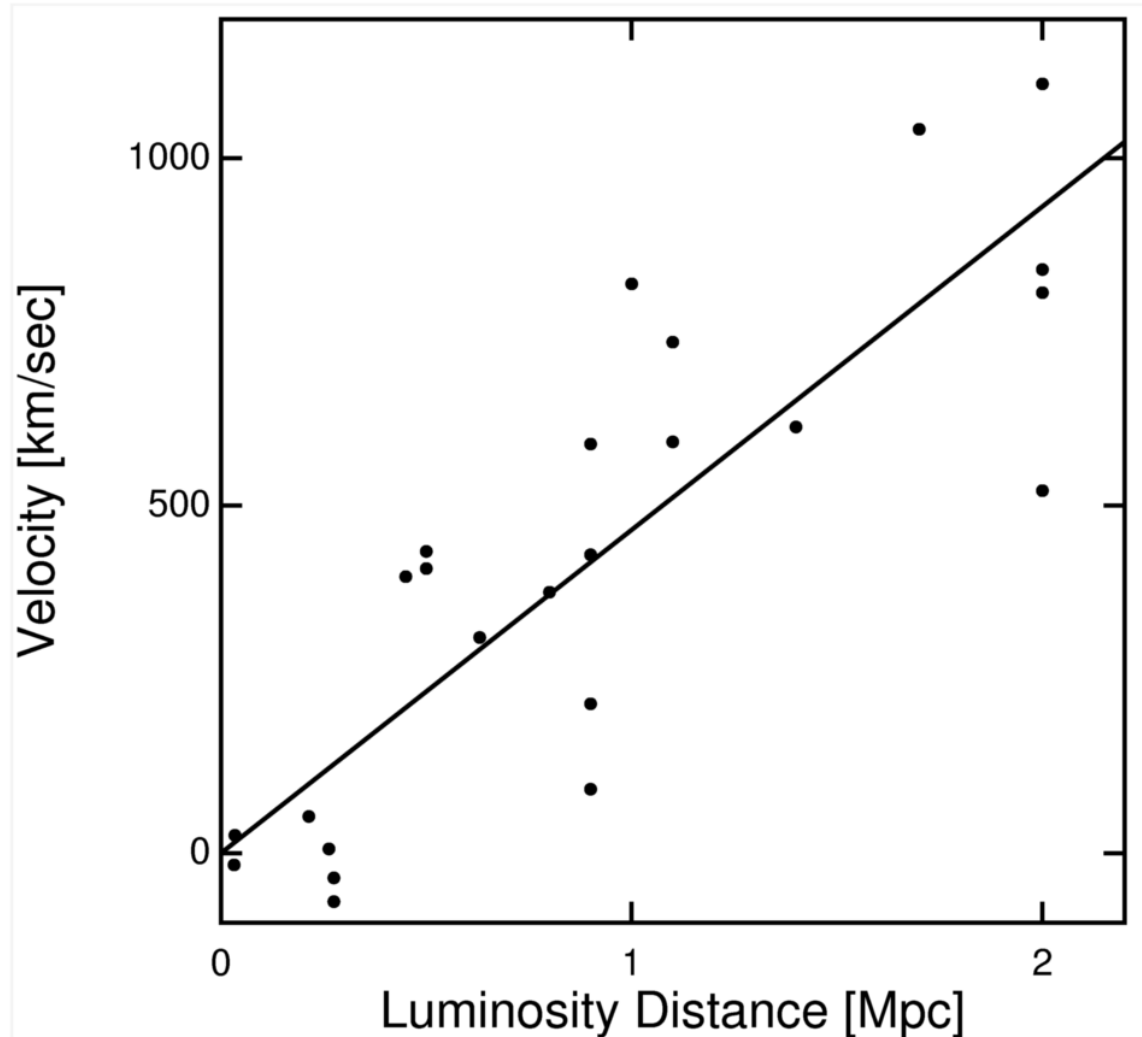

As a result, data on velocity vs distance is now much better! 1995

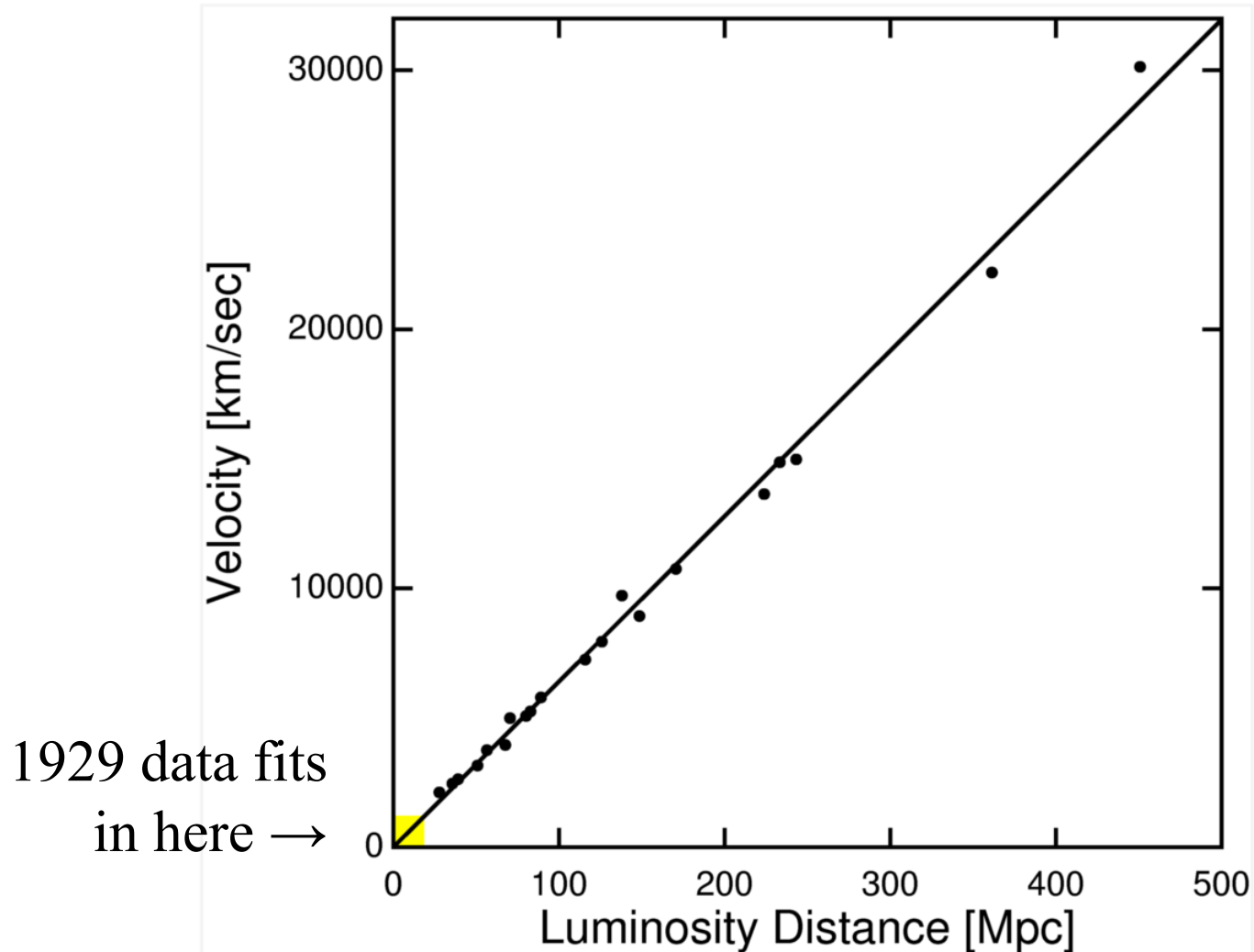

# As a result, data on velocity vs distance is now much better! 2004

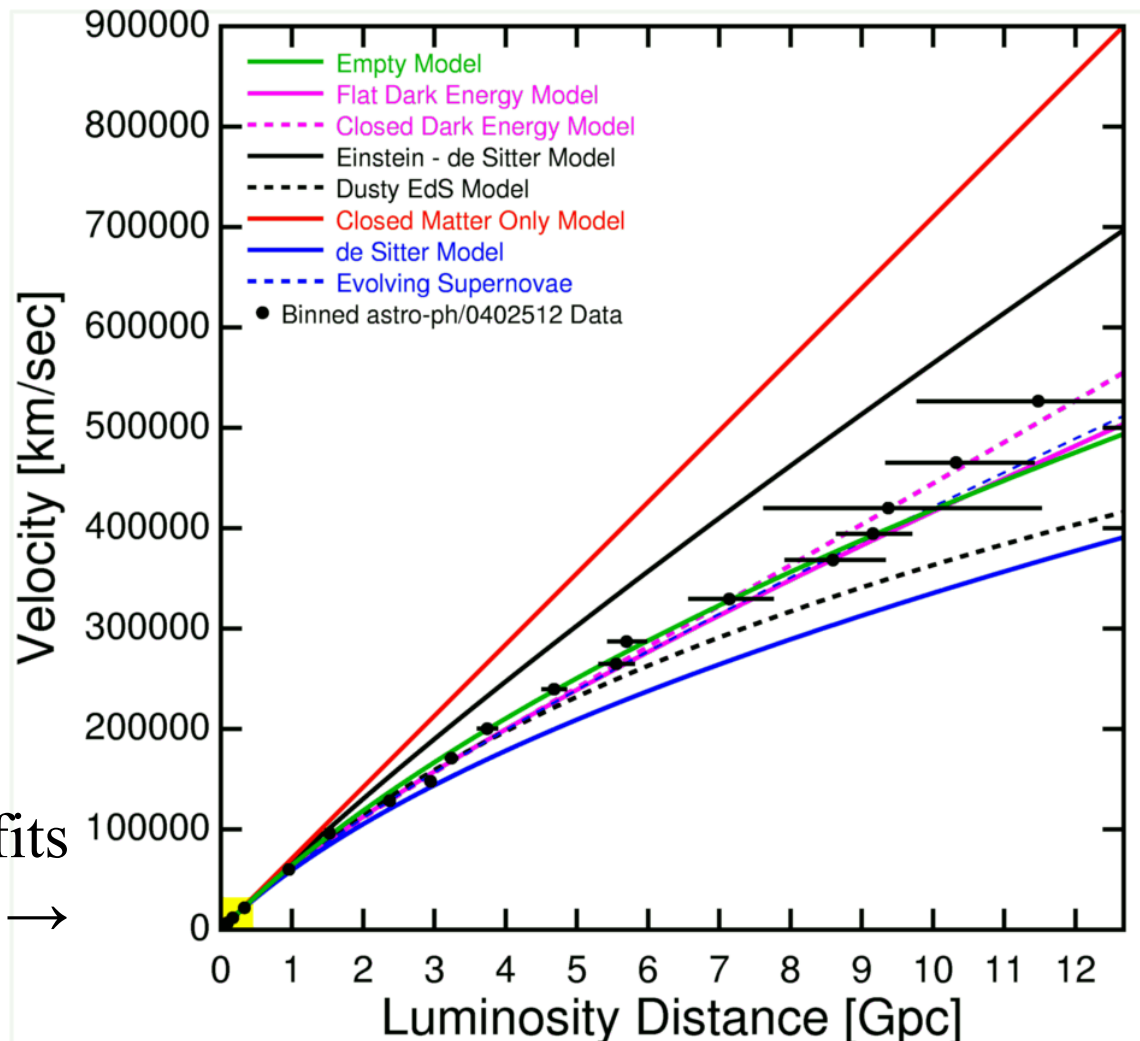

1995 data fits  
in here →

$$v = cz$$

# Gravitational Lensing

- Light is bent by a cluster of galaxies.
- For a symmetric cluster a small faint galaxy can be made into a long and much brighter arc or even a complete ring: the “Einstein ring”

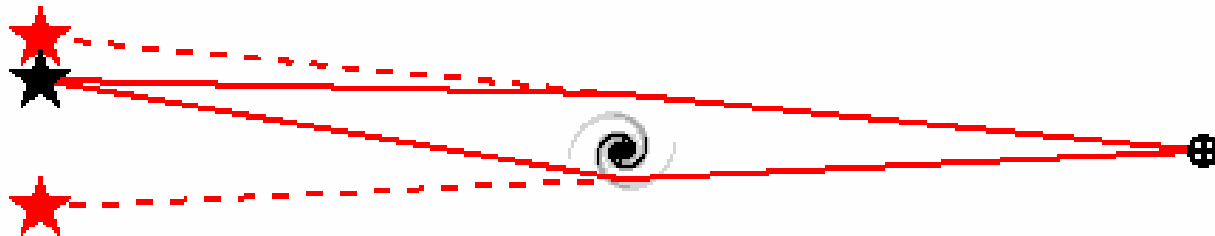
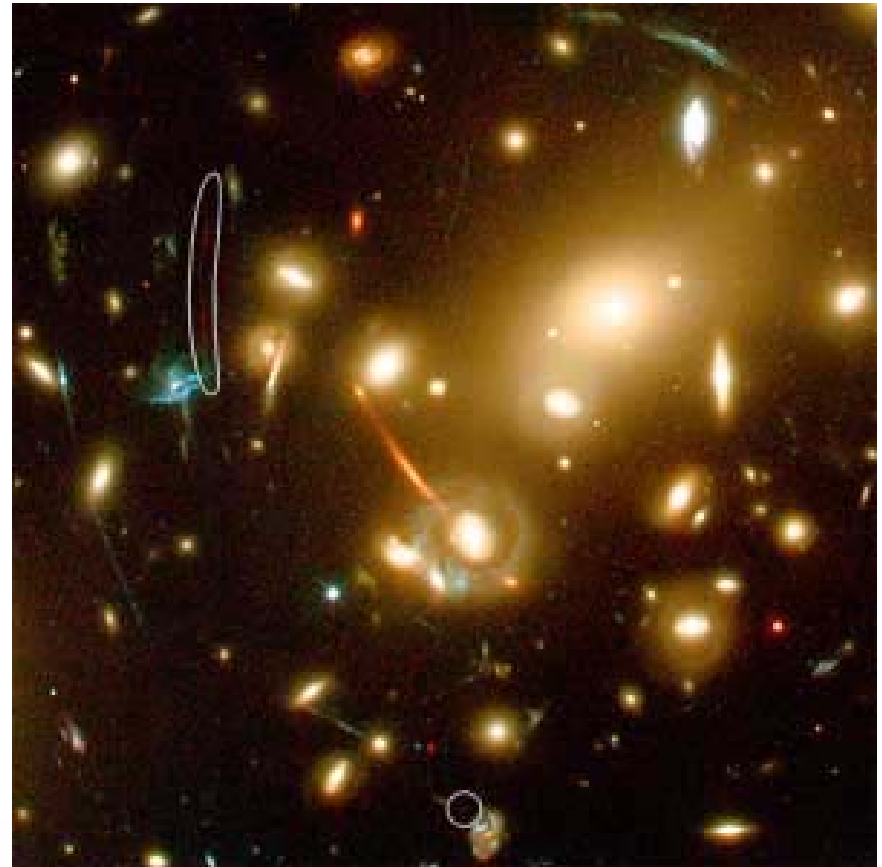

# Cluster Lensing

- This animation shows a foreground cluster of galaxies with the pink showing the projected mass density. It has two separate clumps.
- The blue background galaxies slide behind the cluster to illustrate the range of images that can be produced.

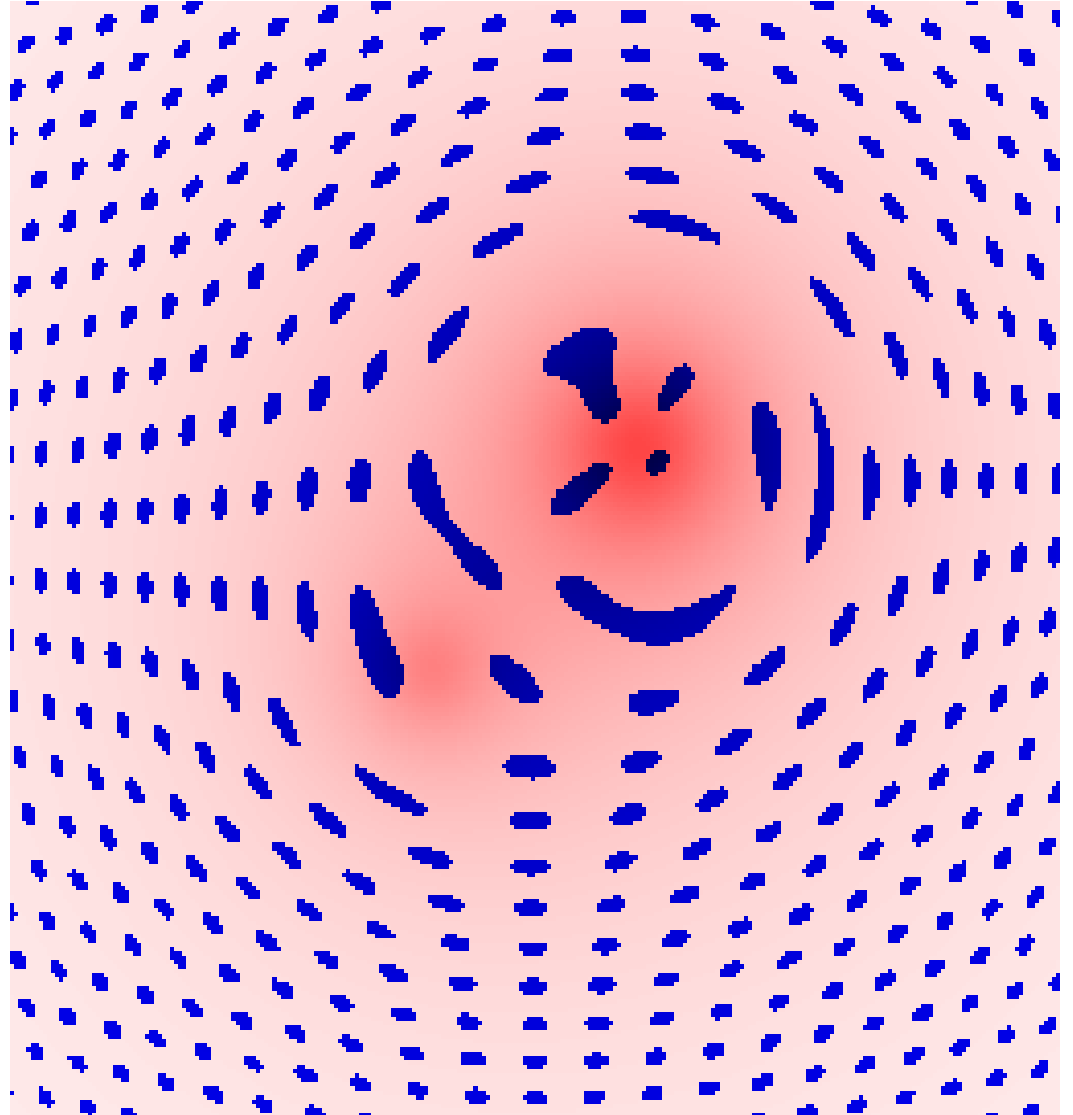



# Einstein Ring Radius vs Distance

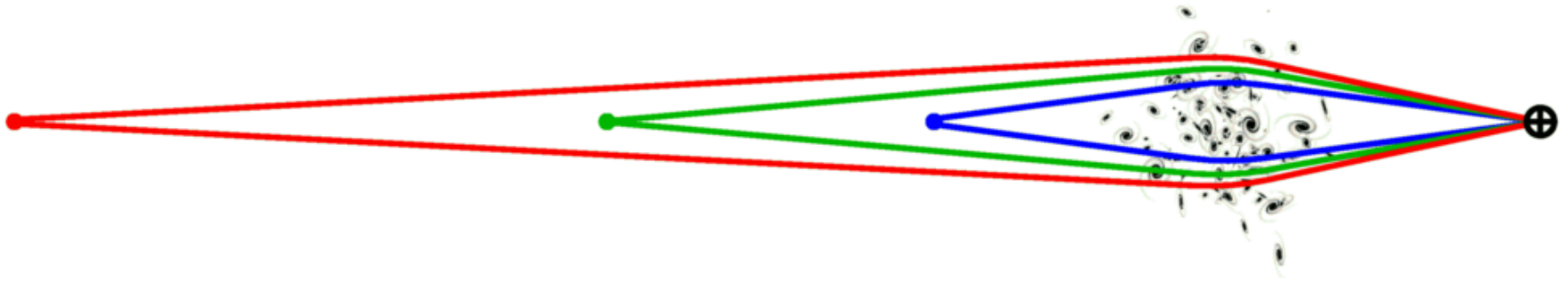

- Radius depends on distance.
- Distance depends on redshift and the geometry of the Universe.

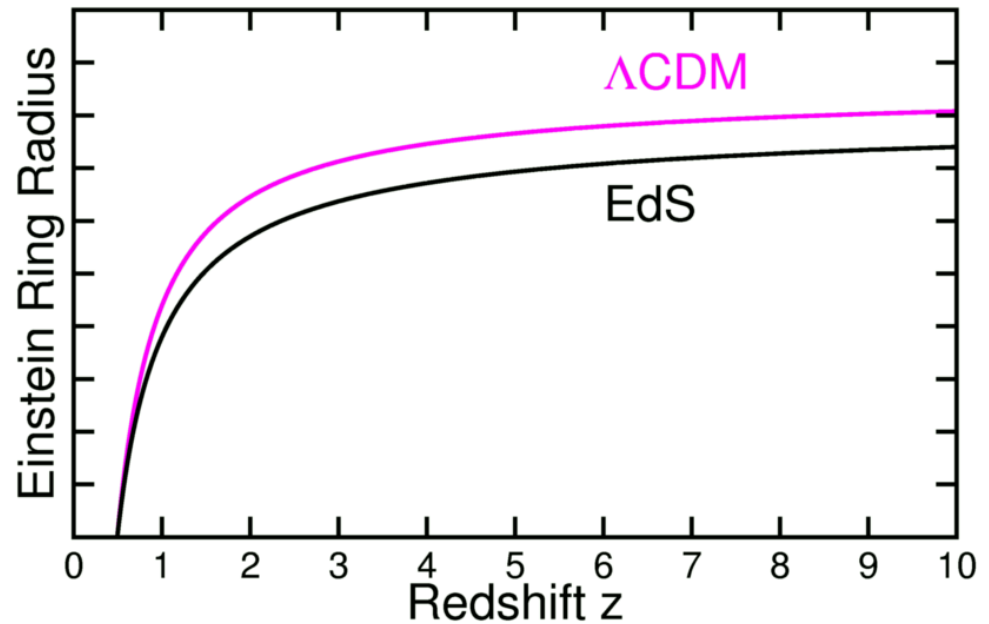

# Can be used to measure Universe

- 4 arcs with well-known redshifts in Abell 2218.
- These arc radii agree more-or-less with the **accelerating Universe** from SNe.

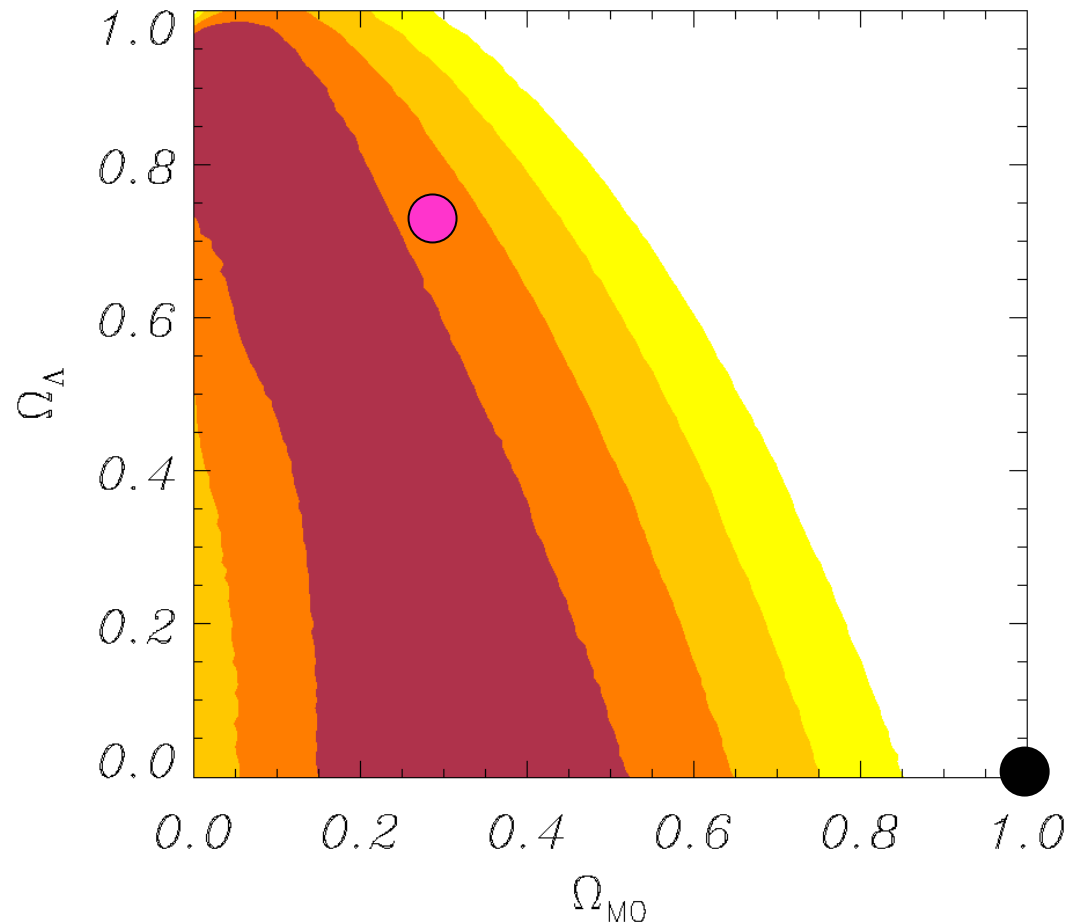

# HUDF Visible

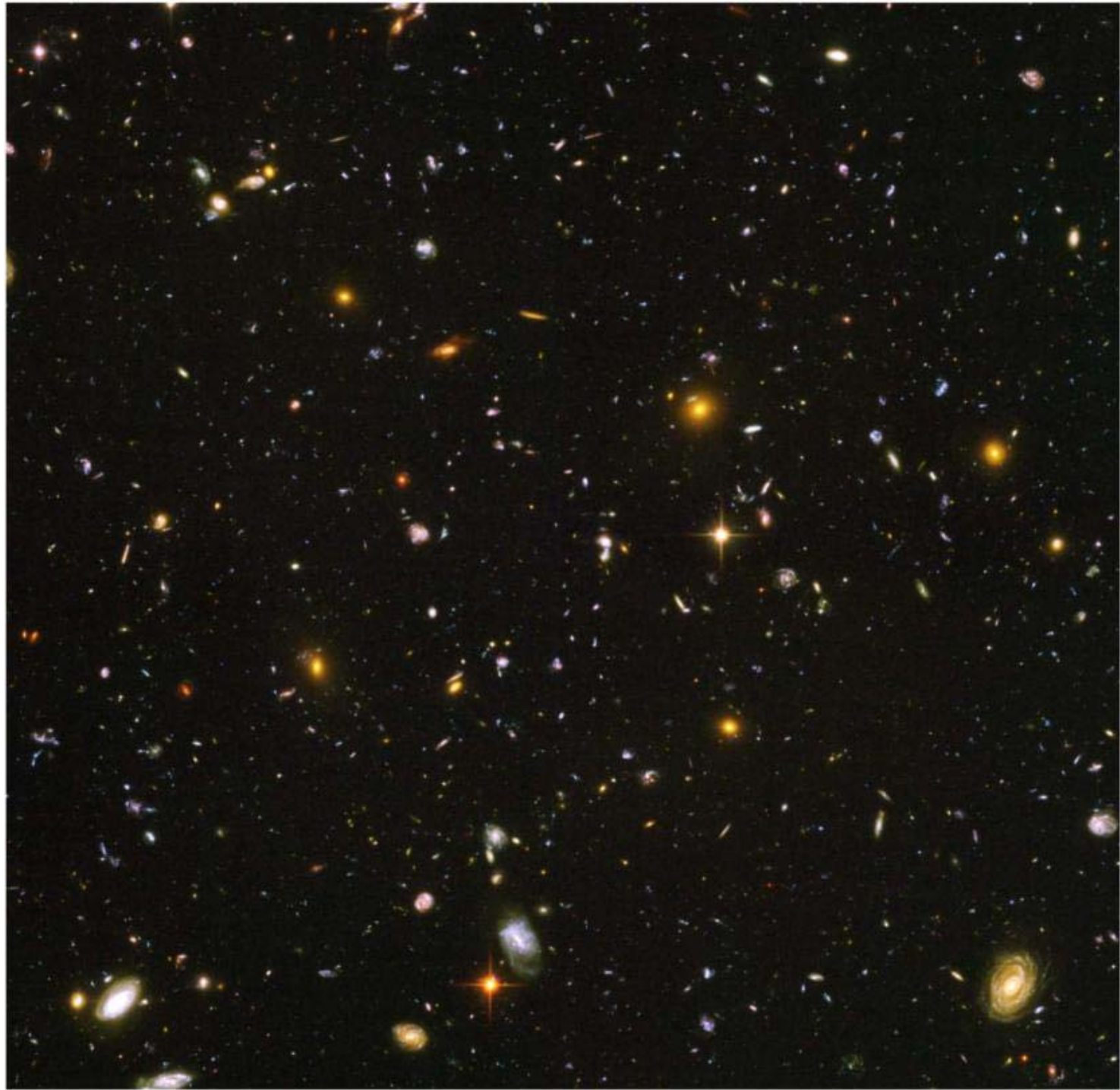



# HUDF Infrared

Note that the IR image has a smaller total exposure time and very much less time on each pixel. But it still goes to higher redshift.

The Hubble Space Telescope has very limited IR capability – NASA needs to move on to the JWST - a bigger and better telescope.

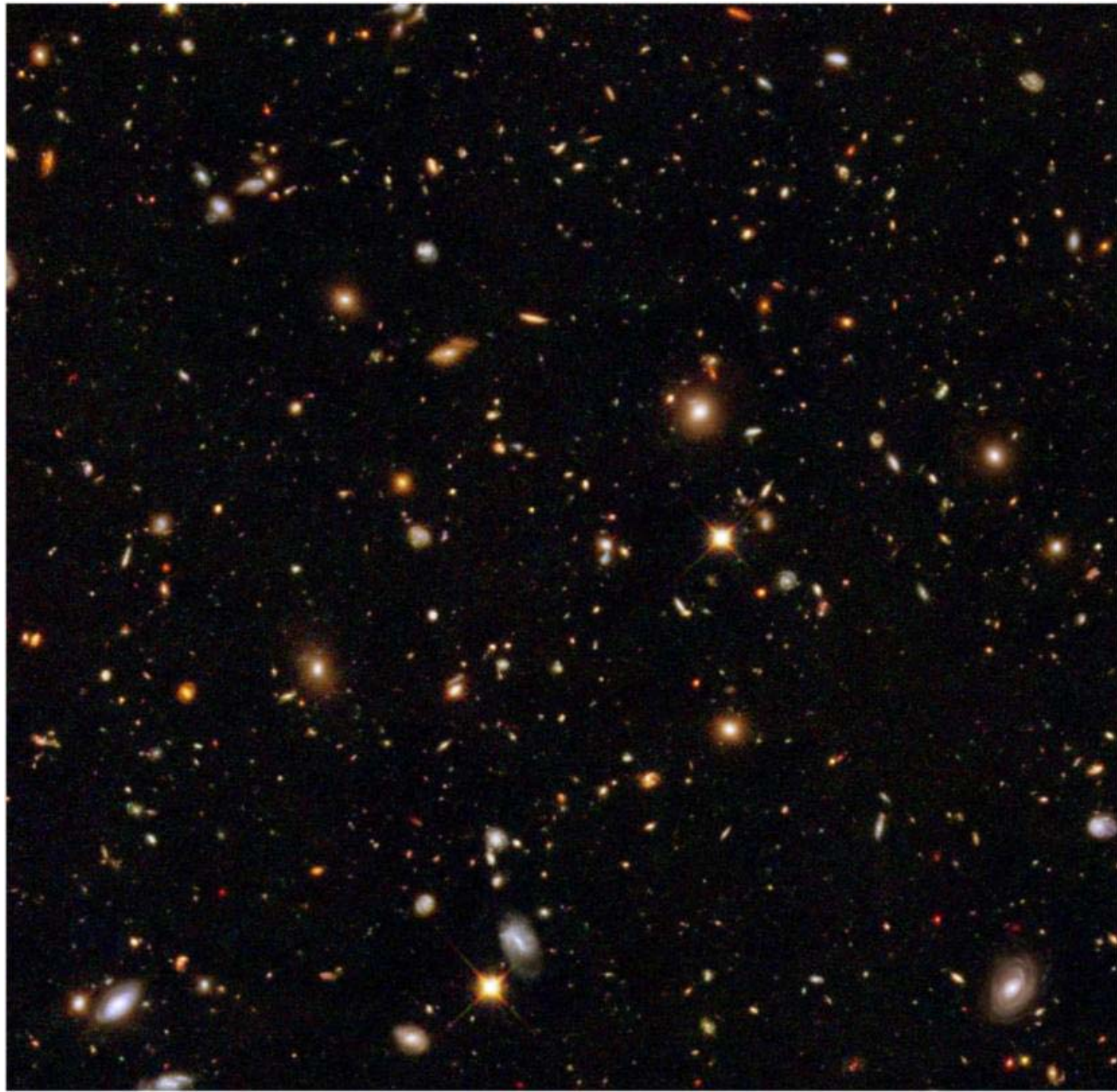

# Late ISW Effect

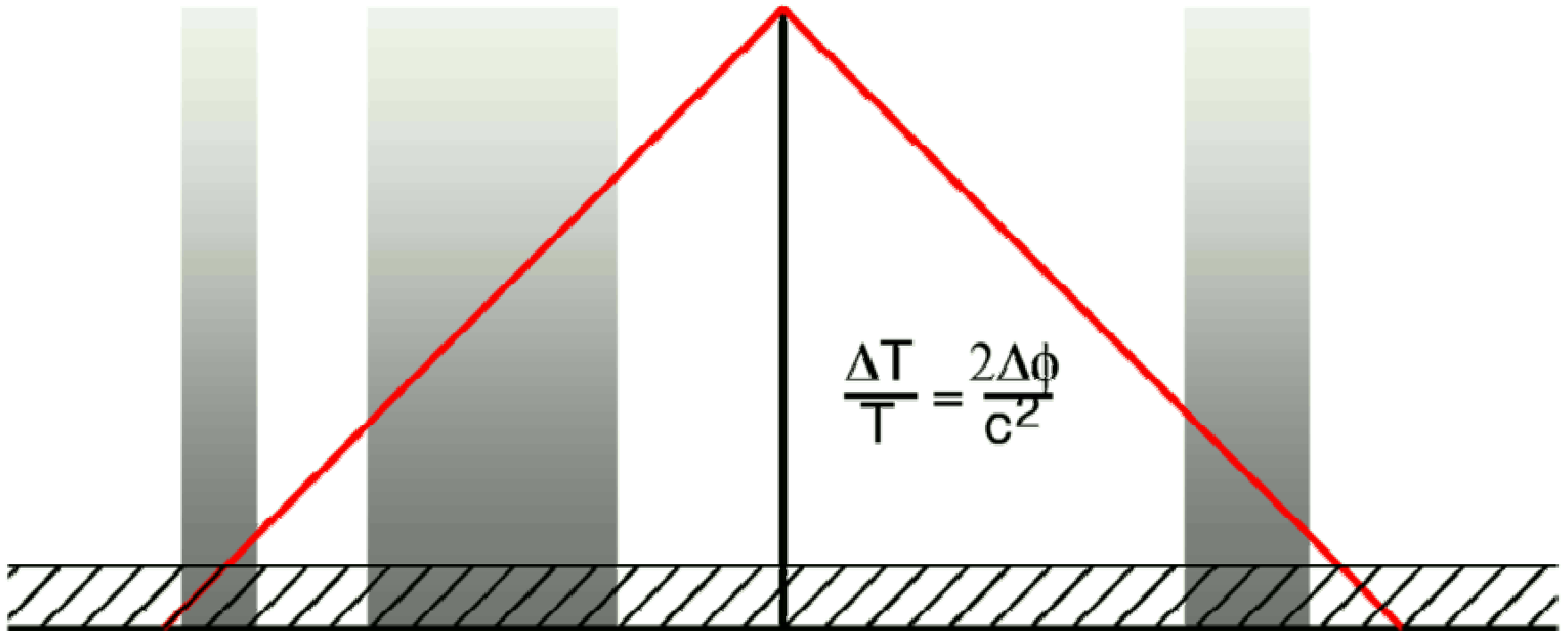

Potential only changes if  $\Omega_m \neq 1$  (or in non-linear collapse, but that's another story [Rees-Sciama effect]).

# Correlation is seen with WMAP

- This late ISW effect occurs on our past light cone so the  $\Delta T$  we see is due to structures we also see.
- Correlation between WMAP and LSS seen by:
  - Boughn & Crittenden (astro-ph/0305001) at  $2.75\sigma$  with hard X-ray background and  $2.25\sigma$  with NVSS
  - Nolta et al. (astro-ph/0305097) at  $2\sigma$  with NVSS

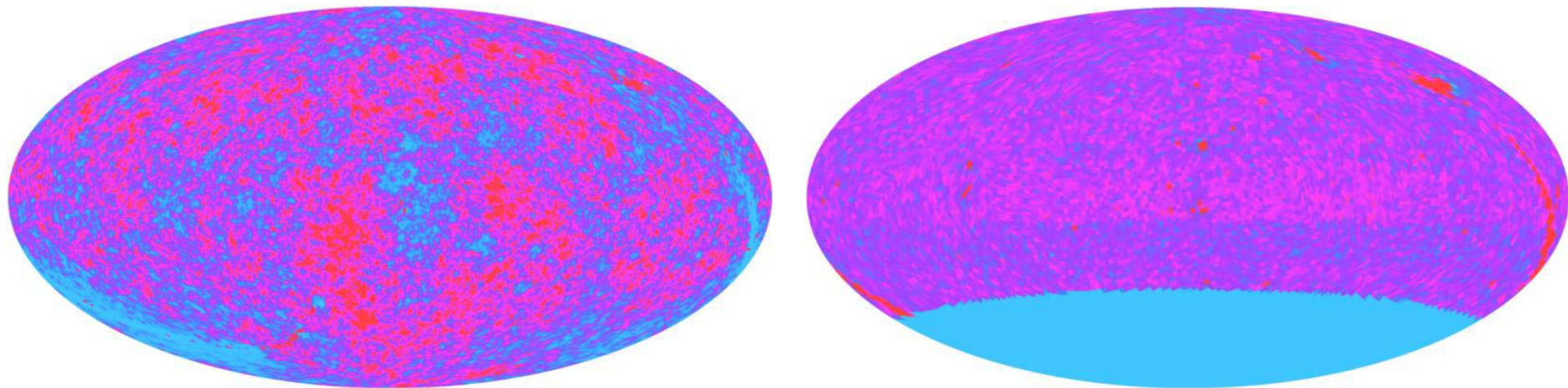



# Possible Improvements?

- ✓ Less noisy and higher resolution CMB data.
  - WMAP is correlated with NVSS & XRB.
- Use a better tracer of LSS. IR surveys trace old stars and thus are close to a mass survey.
- Ashfordi et al (astro-ph/0308260) found  $2.5\sigma$  ISW correlation between WMAP & 2MASS.

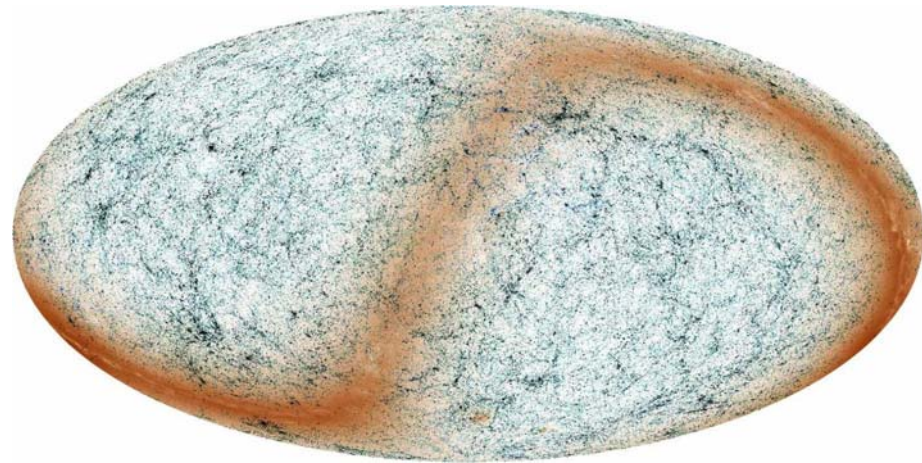
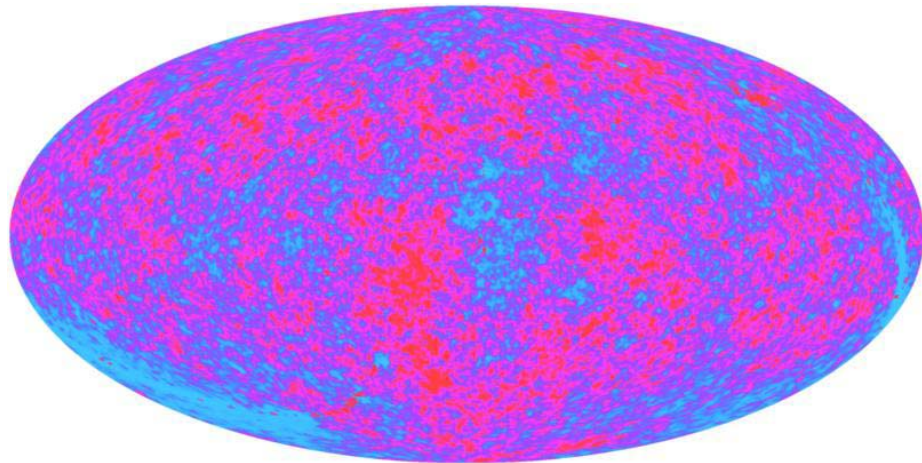

# WIDE-FIELD INFRARED SURVEY EXPLORER

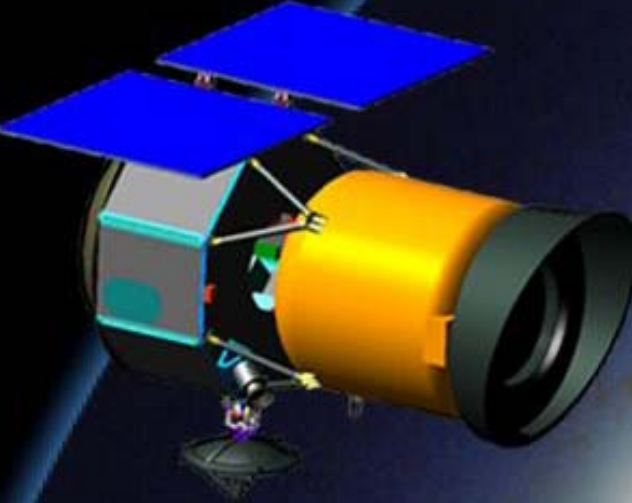

I am the PI on a MIDEX proposal for WISE, an all-sky survey in 4 bands from 3 to 24  $\mu\text{m}$ . WISE will find and study the closest stars to the Sun, the most luminous galaxies in the Universe, and also map the large-scale structure out to redshift  $z=0.7$ , covering the era when the late ISW effect should be generated.

Now in a phase B study, WISE will fly in 4 years if confirmed by NASA.

# Spreading Sphere of Sound

The **baryon-photon** fluid spreads out in an expanding spherical shell surrounding the **cold dark matter** which does not move. After recombination, the Universe becomes transparent and the photons exit the shell, leaving a spherical density enhancement which should show up as a sharp feature in the 3D two-point correlation function at a radius equal to the distance sound could travel before recombination.

This is the same scale involved in the acoustic peaks of the CMB angular power spectrum.

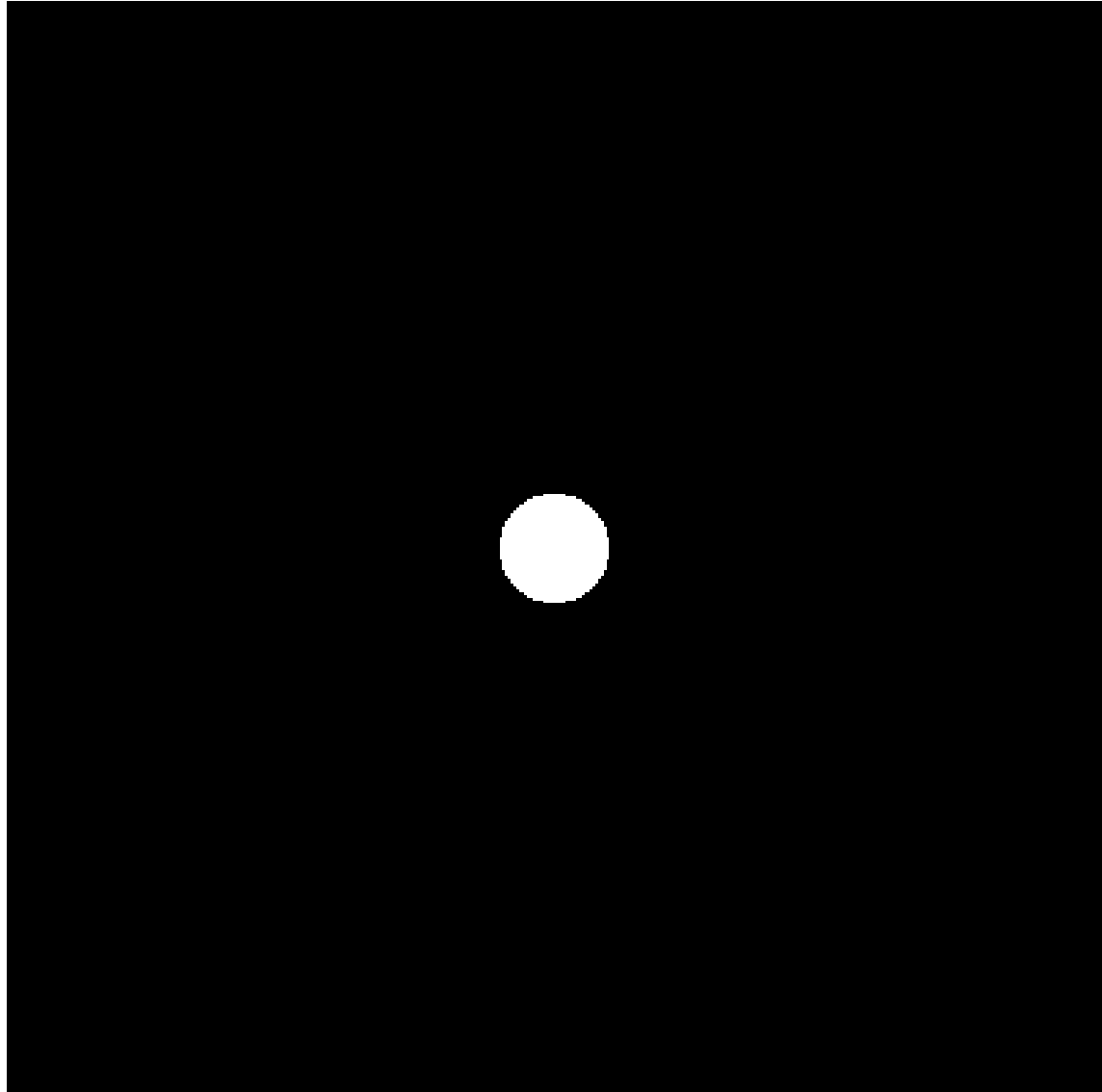

# Baryonic Oscillations in SDSS LRGs

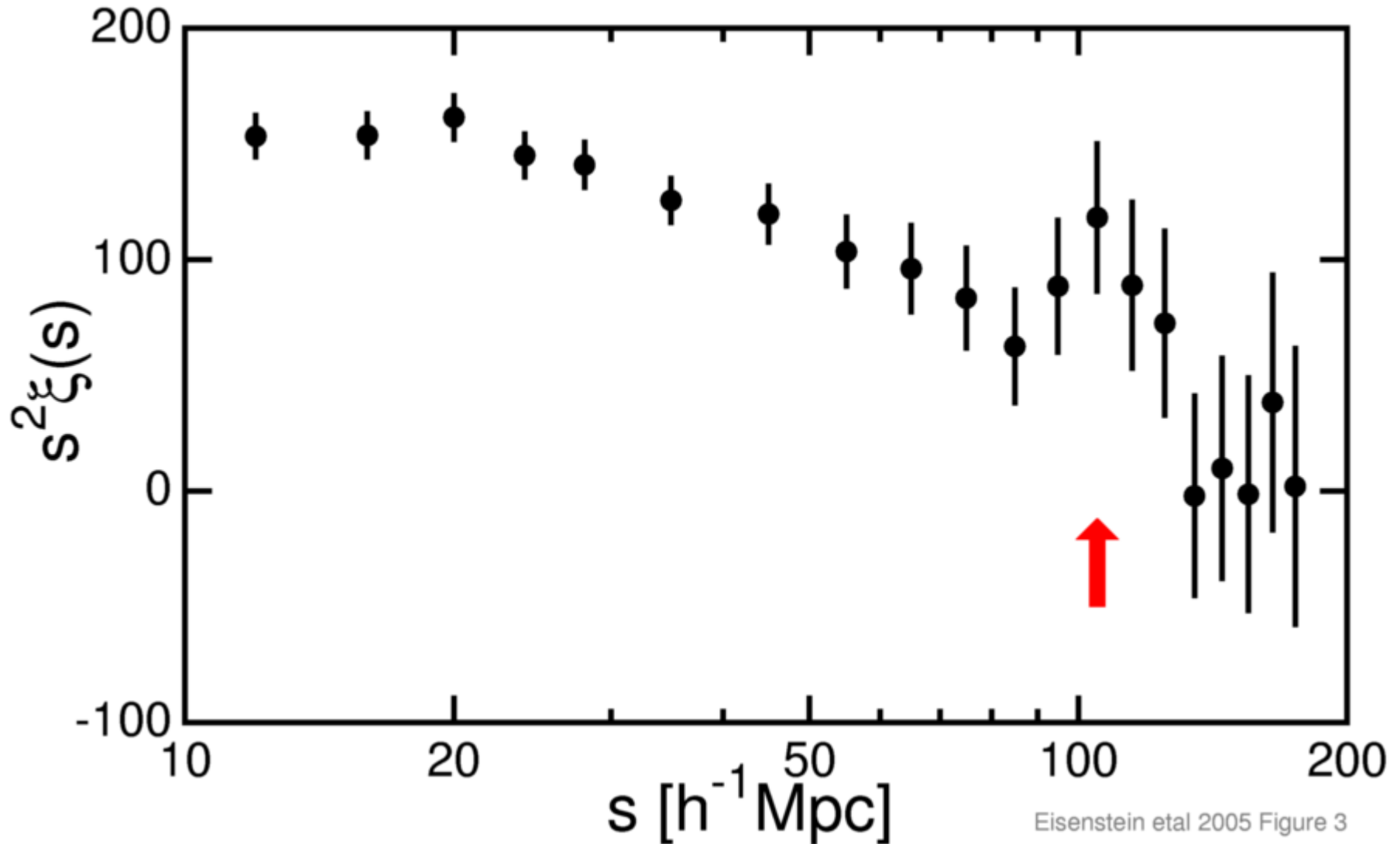



# Implications for $\Omega_M$ , $\Omega_\Lambda$

$H_0$ : 30 40 50 60 70 80 90 100

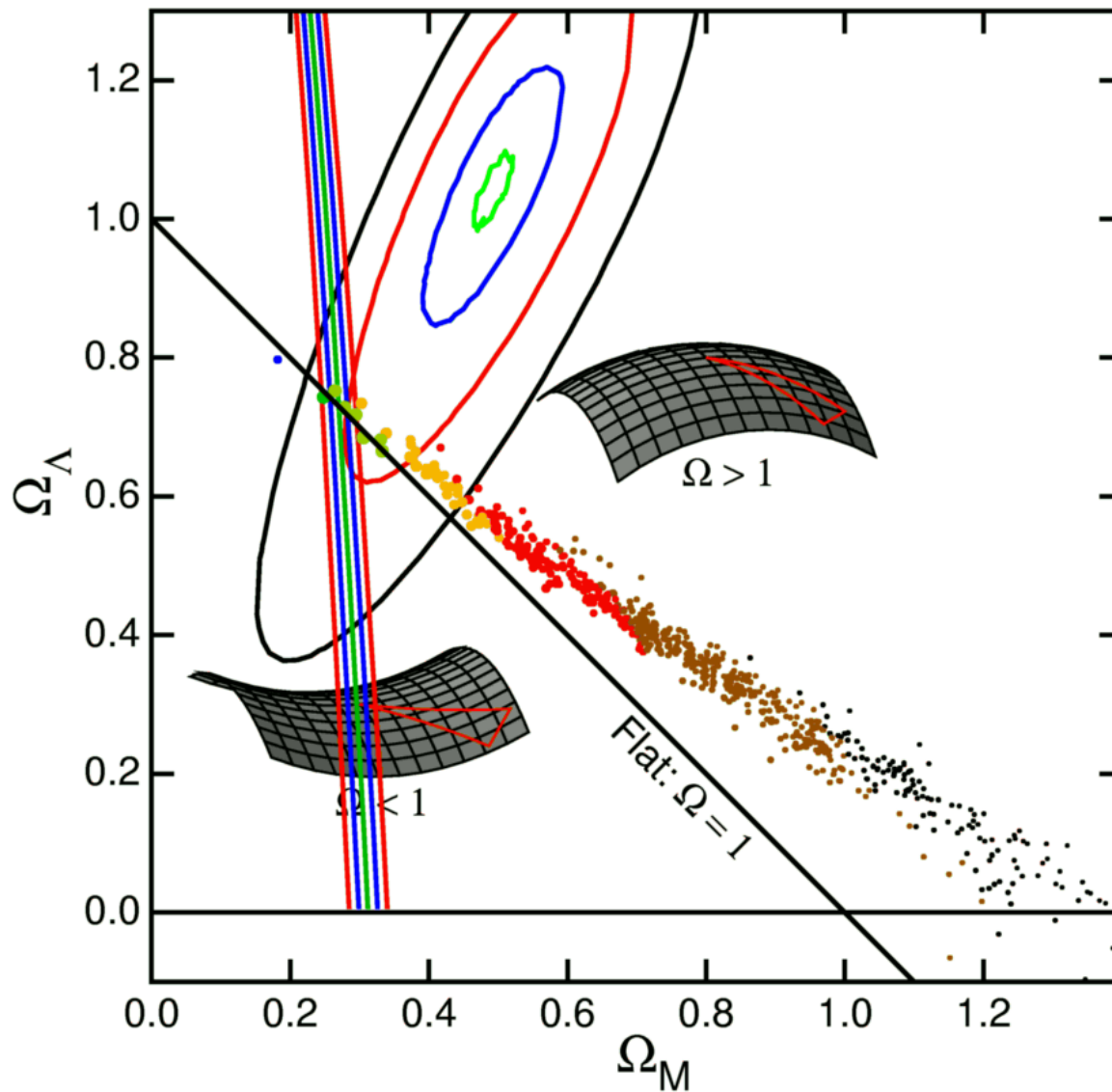

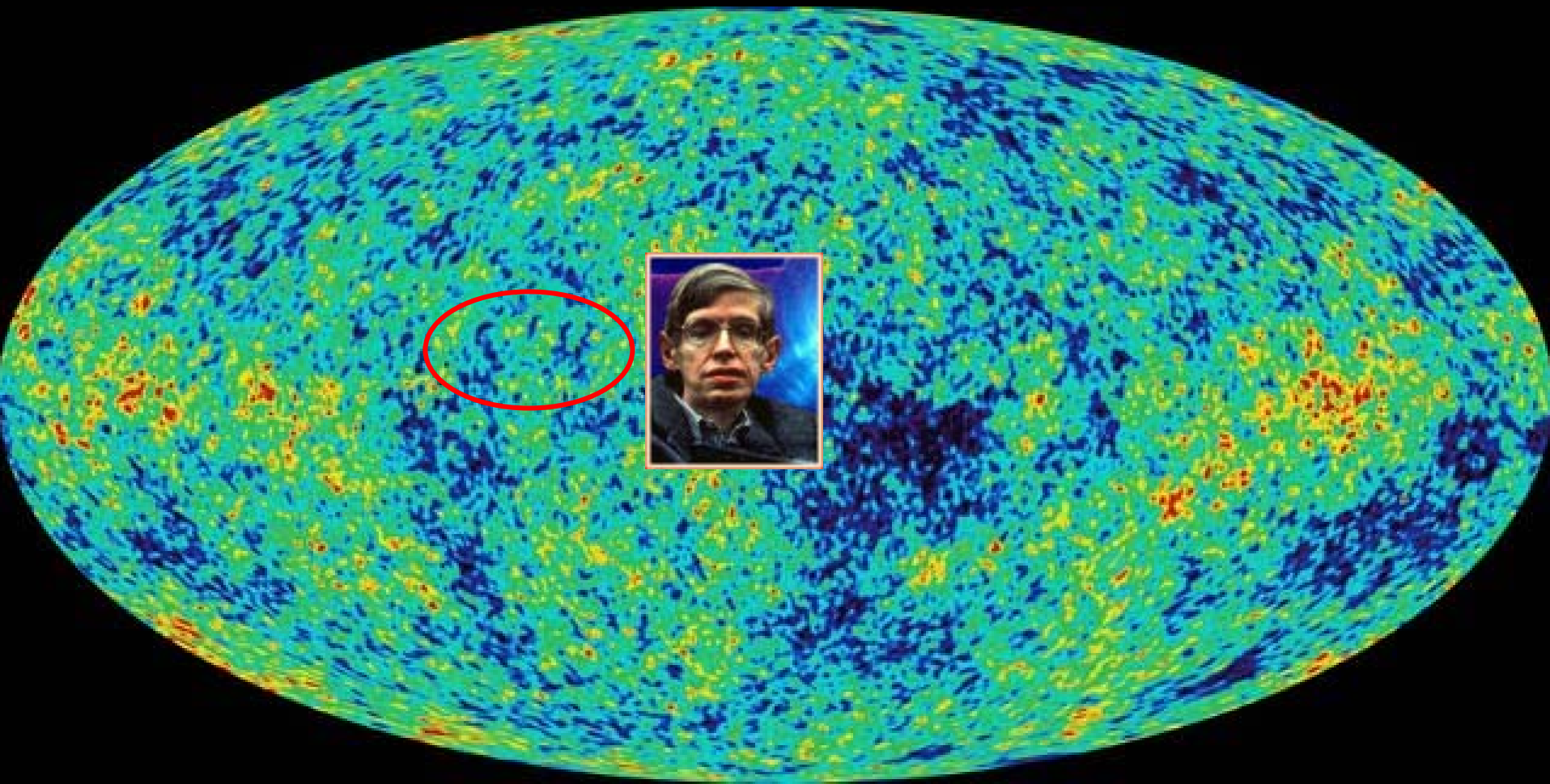



# He knew in '92?

## THE ~~WORLD~~ TIMES

25 April 1992

Prof. Stephen Hawking of Cambridge University, not usually noted for overstatement, said: “It is the discovery of the century, if not of all time.”

