

# The Auger Observatory

The origin and nature of cosmic rays above  $10^{19}$  eV is not understood.

*The Auger Observatory plans to study this phenomenon in a comprehensive way.*

A new laboratory is being built to make a high statistics study of the energy spectrum, direction, composition of cosmic rays above  $10^{19}$  eV.

Two large air shower arrays in:

*Mendoza, Argentina (construction underway)*

*Utah or Colorado, USA (in planning)*

\*\*\*\*\*

Our presentation:

The Status of the Auger Project – P. Mantsch

The Performance of the detectors – J. Cronin

Plans for Auger North – K. Arisaka

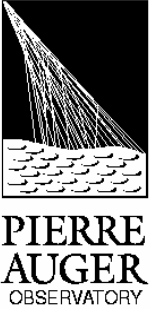

# The Auger Collaboration

**Participating Countries - 50 Institutions, >250 Scientists**

**Argentina**

**Australia**

**Bolivia\***

**Brazil**

**Czech Republic**

**France**

**Germany**

**Greece**

*\*Associate*

**Italy**

**Mexico**

**Poland**

**Slovenia**

**Spain**

**United Kingdom**

**USA**

**Vietnam\***

**Participating US institutions:**

**UCLA**

**Case Western**

**Chicago**

**Colorado**

**Colorado State**

**Fermilab (and ANL)**

**Louisiana State**

**Michigan Tech**

**Minnesota**

**Nebraska**

**New Mexico**

**Northeastern**

**Penn State**

**Utah**

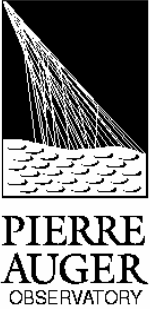

# The Auger Observatory

*The Auger Observatory combines the strengths of*

## **Surface Detector Array and Air Fluorescence Detectors**

- Independent measurement techniques allow control of systematics
- More reliable energy and angle measurement
- Primary mass measured in complementary ways



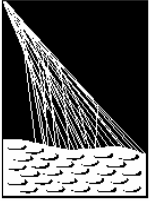

PIERRE  
AUGER  
OBSERVATORY

## The Observatory Plan

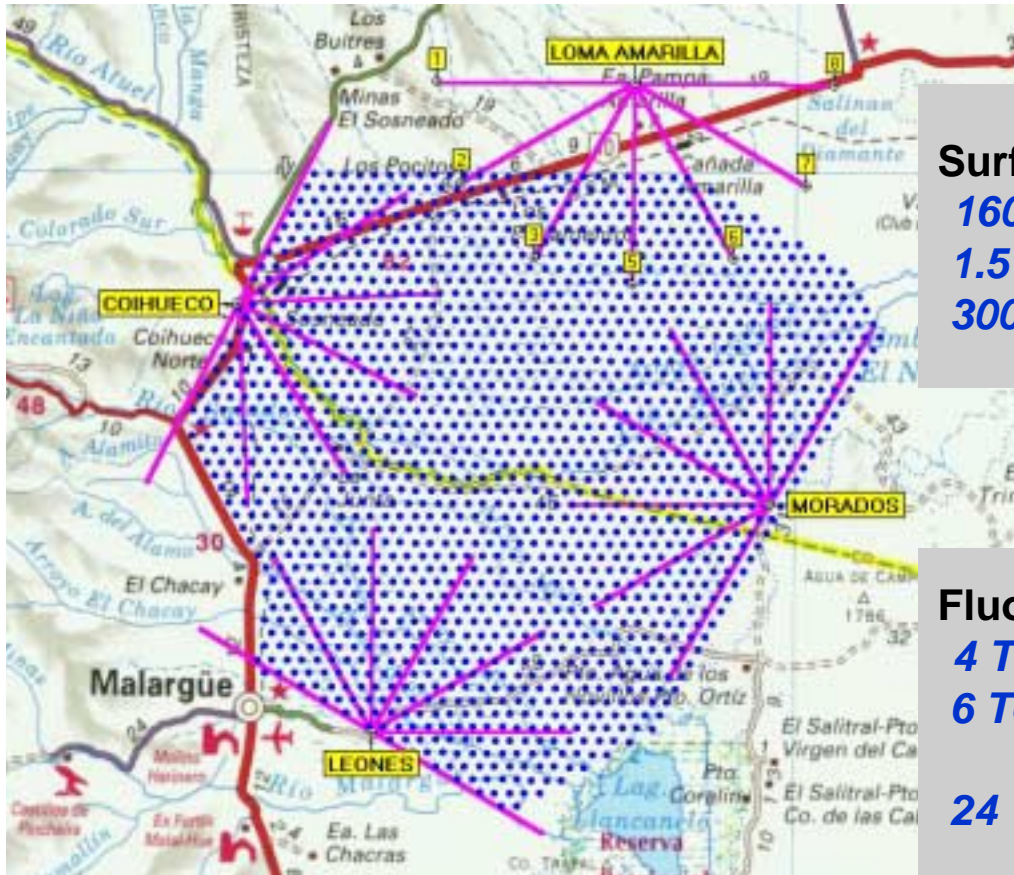

**Surface Array**  
*1600 detector stations*  
*1.5 Km spacing*  
*3000 Km<sup>2</sup>*

**Fluorescence Detectors**  
*4 Telescope enclosures*  
*6 Telescopes per enclosure*  
*24 Telescopes total*

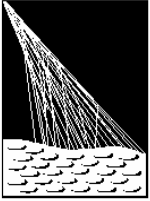

PIERRE  
AUGER  
OBSERVATORY

# Construction Plan

## Years 2000 & 2001

**Engineering Array (32 surface detector stations/2 prototype fluorescence detectors)**

*Validated observatory design  
Tested performance of all systems in the field  
Provided a basis for refinements in the design, cost and schedule.*

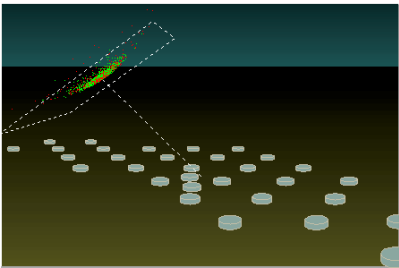

## Year 2002 – 2003

**Pre-production**

*Qualified production vendors for dependability and quality.*



## Year 2003 – 2005

**Full production and deployment**



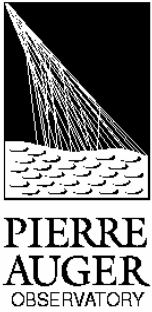

# The Fluorescence Detectors

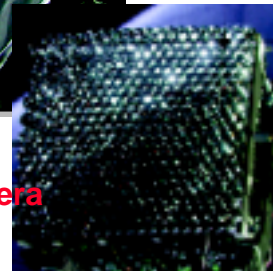
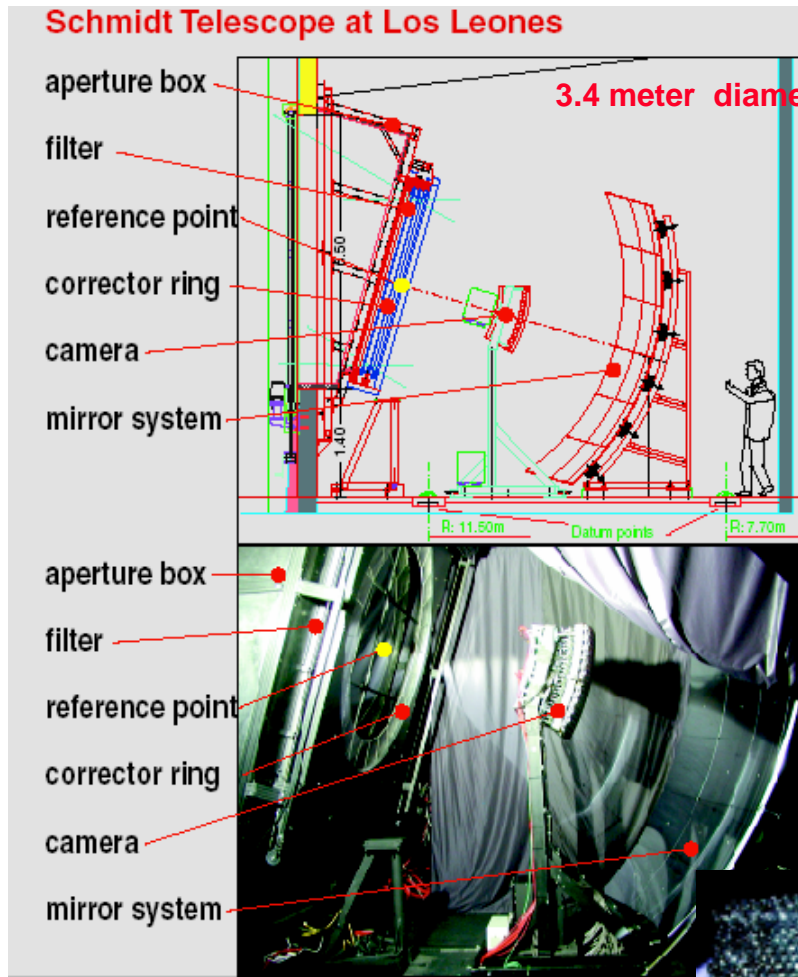

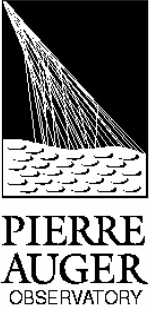

# Atmospheric Monitoring and Calibration

To realize the full advantage of the calorimetric fluorescence measurement, absolute calibration and careful atmospheric measurements are necessary.

- **Atmospheric Monitoring**
  - *Lidar for atmospheric profiling and “shooting the showers” (atmospheric measurement along the shower path).*
  - *Fixed vertical and steerable lasers at array center for atmospheric monitoring, timing and calibration checks.*
  - *Continuous horizontal attenuation monitors.*
  - *Balloon borne atmospheric measurements.*
- **Absolute Calibration**
  - *End to end absolute calibration*



Lidar at each Fluorescence



Central Laser Facility (laser optically linked to adjacent surface detector tank)

Drum for uniform illumination of each fluorescence camera – part of end to end calibration .



Year around balloon borne atmospheric measurements.



# The Surface Array

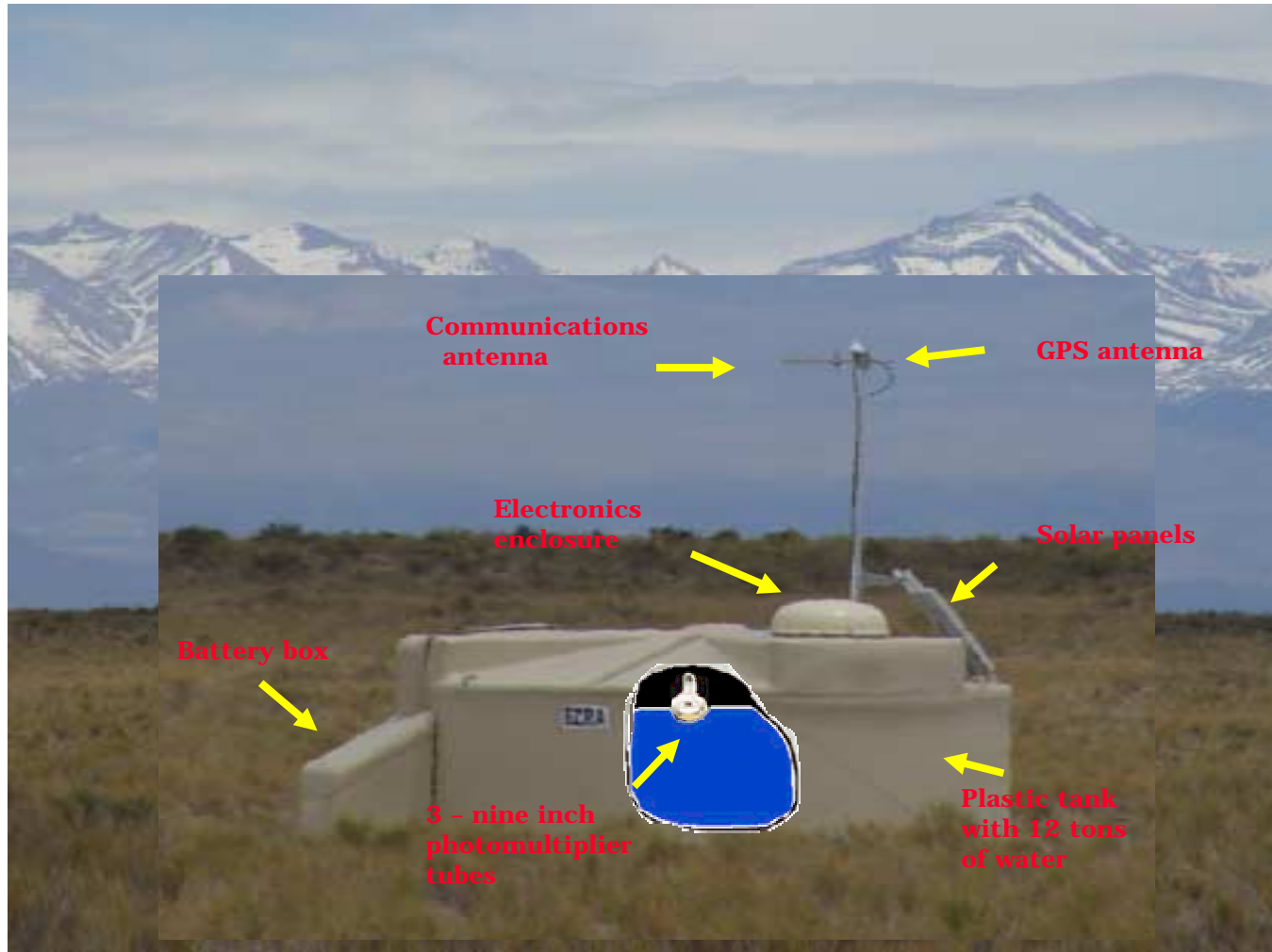

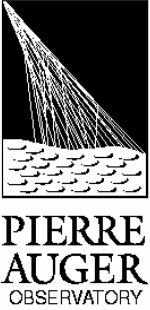

# Typical Event

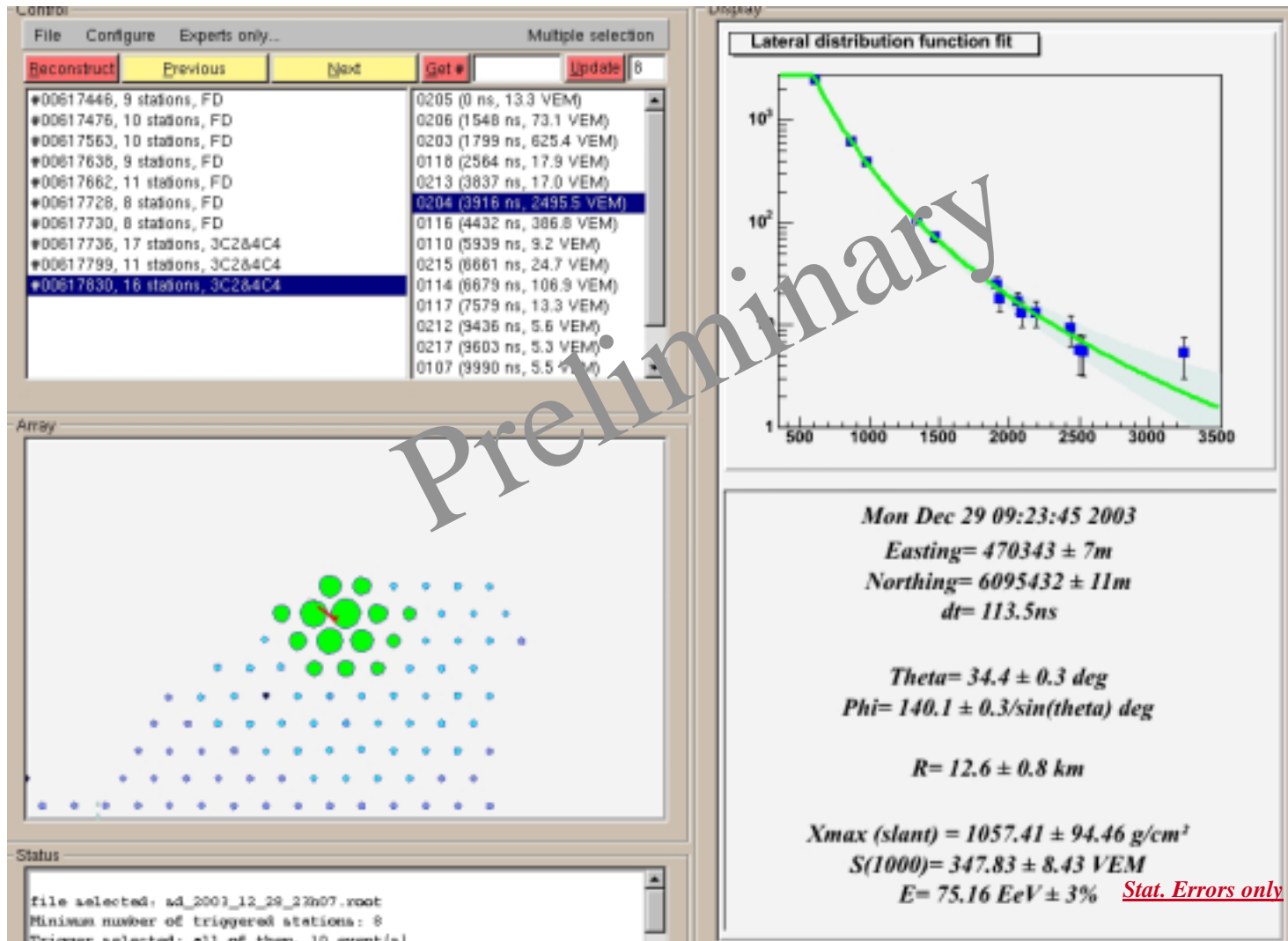

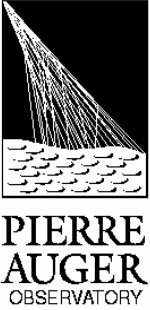

# Typical Event Con't

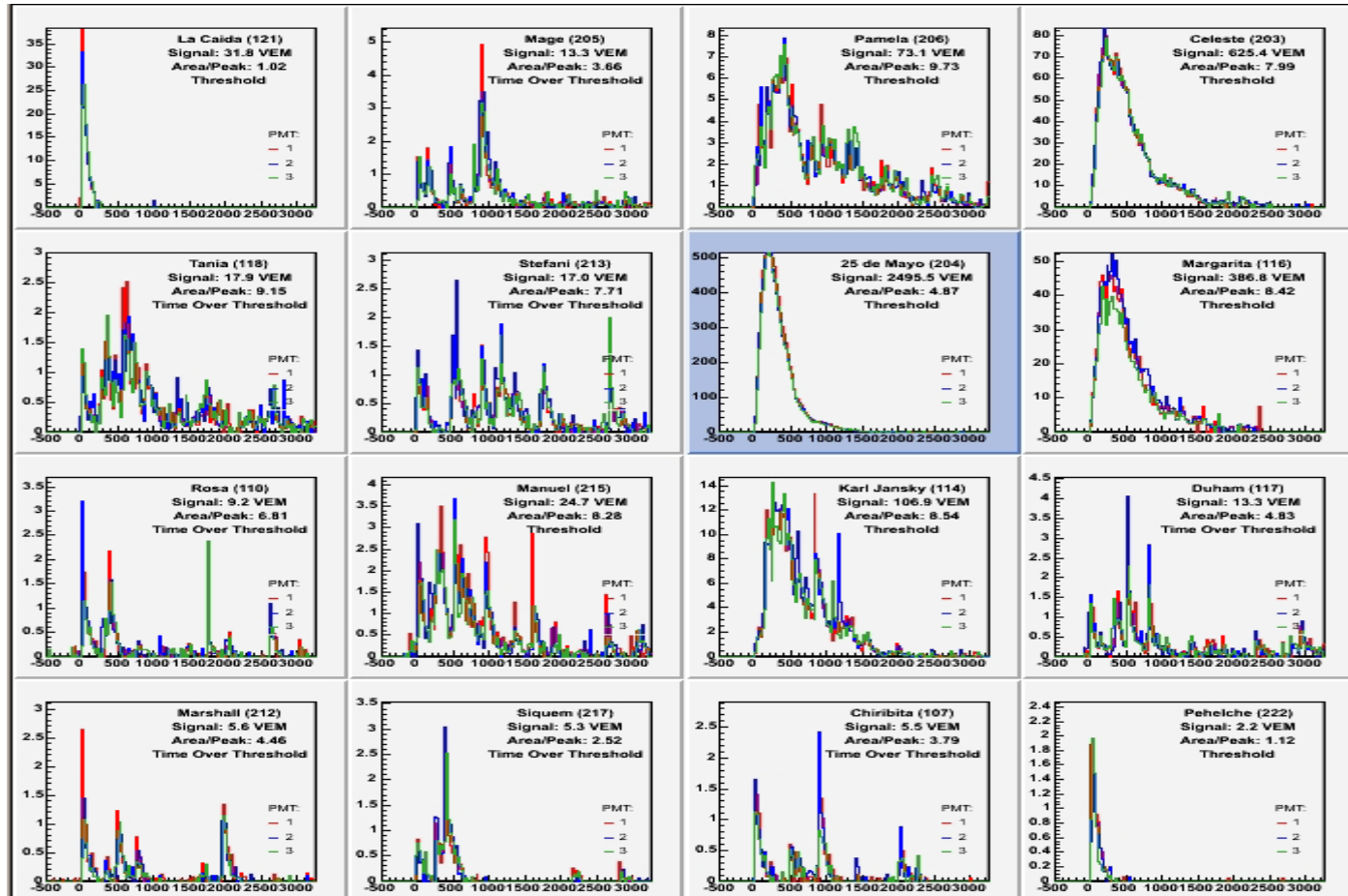

PRELIMINARY analysis shows  
zenith angle  $34^\circ$ , energy 75 EeV

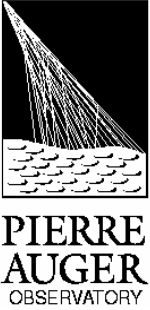

# Status



Coihueco

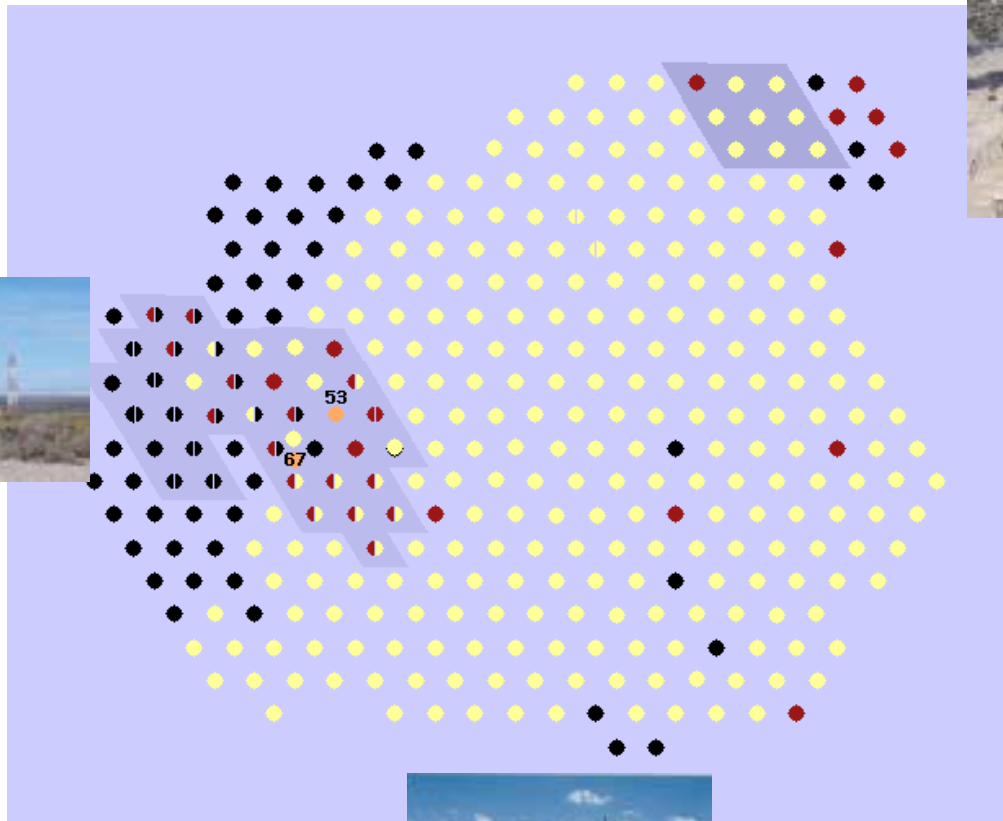

Los Morados

## Surface Array

- 350 surface detector stations deployed
- 270 surface detector stations have electronics and are operational – ***World's largest array!*** 

## Fluorescence detectors

- 6 telescopes operational in Los Leones
- 2 telescopes operational in Coihueco



Los Leones

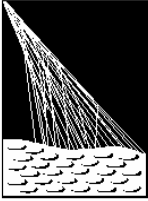

PIERRE  
AUGER  
OBSERVATORY

# Progress

**All of the observatory systems have met or exceeded our expectations –**

– **Fluorescence**

- *Hybrid reconstruction works better than anticipated.*
- *Double (stereo) and triple hybrid events at high energy add precision and systematic checks.*

– **Surface Array**

- *Lower threshold – greater sensitivity*
- *Anisotropy studies possible well below  $10^{19}$  eV.*
- *Reconstruction possible for events to zenith angles of almost 90 degrees*
  - Greater Aperture (~x2 compared to aperture below 60 degrees)
  - Extends sensitivity to neutrinos and possibly exotics at high zenith angle.

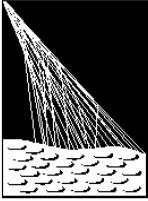

PIERRE  
AUGER  
OBSERVATORY

# Cost and Funding

**Auger South Total Project Cost:**

**March 99 - \$54.6M**

**October 01 - \$53.8M**

**January 04 - \$47.5M**

**However, available funding reduced by about \$10M as a result of the collapse of the Argentine economy as well as financial problems in Brazil and Mexico.**

**The participating countries have been asked to make up this shortfall –  
In hand - \$2M, likely additional - \$6M, requests pending - \$2M**

***Connecting Quarks with the Cosmos (NAS – Turner Report):  
Eleven Science Questions for the New Century –  
Recommendation:***

***“Determine the origin of the highest energy gamma rays, neutrinos and cosmic rays.  
The Committee supports the broad approach already in place,  
and recommends that the United States ensure the timely  
completion and operation of the Southern Auger array.....”***

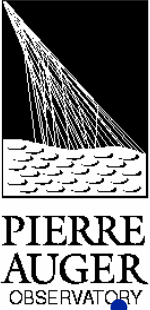

# Summary

- **We have formed a broad international collaboration that has successfully begun the construction of the Southern site of a new cosmic ray air shower observatory at a remote location in Argentina.**
- **The Auger Observatory uses a unique and powerful hybrid technique to address one of the important science questions of our time.**
- **The detectors have demonstrated performance beyond our expectations.**
- **With adequate funding the observatory will be complete at the end of 2005.**